



FEATHER RIVER RECREATION & PARK DISTRICT
Special Board Meeting
October 4, 2023

ACTIVITY CENTER
1875 Feather River Blvd.
Oroville, CA 95965

AGENDA

10:00am Open Session

Written comments must be sent to KendyleL@frrpd.com 1-hour prior to the meeting to be presented to the Board. If you need special accommodations to participate in this meeting, please contact (530)533-2011.

CALL MEETING TO ORDER

ROLL CALL

Chairperson Shannon DeLong
Vice-Chairperson Scott "Kent" Fowler
Director Devin Thomas
Director Clarence "Sonny" Brandt
Director Greg Passmore

PLEDGE OF ALLEGIANCE

CLOSED SESSION

1. Pursuant to Government Code section 54957 (b) (1): Personnel Exception

PUBLIC COMMENT

The Board will invite anyone in the audience wishing to address the Board, on a matter not listed on the agenda, to state your name for the record and make your presentation. You are limited to three (3) minutes. *The Board cannot take any action except for a brief response by the Board or staff to a statement or question relating to a non-agenda item.*

ACTION ITEM(S)

1. **Review And Select Bid For Bedrock Tennis Court Lighting** (Appendix A)
Motion:
Vote:
2. **Approved The Updated Board Policies And Procedures** (Appendix B)
Motion:
Vote:
3. **Allow the General Manager to Have The Authority to Negotiate the Union Contract** (Appendix C)
Motion:
Vote:

ADJOURNMENT



STAFF REPORT

DATE: October 4, 2023

TO: FRRPD Board of Directors

FROM: Joe Velasquez, Park Supervisor

RE: Contract Award Notice for Bedrock Tennis Court Lighting Project

SUMMARY

Three contractors submitted bids for the Bedrock Tennis Court Lighting Project. See attached bids.

BUDGETARY IMPACT

- Paine Construction: \$46,250
- Sactown Contractors: \$53,209
 - Alternative bid: \$161, 877
- Williams Electric Company: \$63,250.30

RECOMMENDATION

Williams Electric Company, based on prior work completed, following RPF request, and scope of work to be provided.

ALTERNATIVE ACTIONS

Choose one of the alternative bidders.

ATTACHMENTS

1. RFP: Paine Construction:
2. RFP: Sactown Contractors:
3. RFP: Williams Electric Company:



7212 8th St, Rio Linda, CA, 95673
 (916-889-3840) (916-868-1083)
 CSLB# 333880 B,C-10,13,15,33
 DIR:PW-LR-1000434239
 SB(Micro):# 2012794

PROPOSAL

JOB NAME BEDROCK TENNIS COURTS LIGHTING UPGRADE	PROPOSAL DATE 09/08/2023
LOCATION 1875 Feather River Blvd. Oroville, CA 95965	ADDENDUM(S) 01

We propose hereby to furnish material and labor necessary for the completion of:
This proposal includes the following per plans, specifications, & Addendums:

BEDROCK TENNIS COURTS LIGHTING UPGRADE

Description	Qty	Price	Total
1.) Light pole inspection (does not include replacement)	9	\$110	\$990
2.) Electrical Wire Replacement on pole	9	\$500	\$4,500
3.) Conduit Inspection and replacement on pole	9	\$440	\$3,960
4.) Inspect mount, replace if necessary	24	\$410	\$9,840
5.) Replace 24 lights with LED lights	24	\$790	\$18,960
6.) Electrical Panel Upgrade	1	\$5,000	\$5,000
7.) Light Adjustment	24	\$125	\$3,000

Includes Prevailing Wage Rates. Hourly rate: \$110 regular, \$140 1 1/2, \$180 double time

We propose hereby to furnish material and labor – complete in accordance with above specifications for the sum of:
Fourty Six Thousand Two Hundred Fifty dollars (\$ **46,250.00**)

Payment as follows: **Net 30**

All material is guaranteed to be as specified. All work to be completed in a substantial workmanlike manner according to specifications submitted, per standard practices. Any alteration or deviation from above specifications involving extra costs will be executed only upon written orders, and will become an extra charge over and above the estimate. All agreements contingent upon strikes, accidents or delays beyond our control. Owner to carry fire, tornado and other necessary insurance. Our workers are fully covered by Workmen’s Compensation Insurance.

Authorized

Name Mark Zaychenko **Signature** 

Note: this proposal may be withdrawn by us if not accepted within 90 days.

ACCEPTANCE OF PROPOSAL The above prices, specifications and conditions are satisfactory and are hereby accepted. You are authorized to do the work as specified. Payment will be made as outlined above.

Name _____

Signature _____

Date of Acceptance _____





The SCOPE OF WORK includes:

Unit	Description	Qty	Price	Total
1.0	Light pole inspection, evaluation, and determination of condition. Advise on whether they are good or need replaced.	9	\$110	\$990
2.0	Electrical wire replacement on pole	9	\$500	\$4,500
3.0	Conduit inspection on all poles, replacement if needed.	9	\$440	\$3,960
4.0	Inspect light mounts, replace as necessary.	24	\$410	\$9,840
5.0	Replace 24 fluorescent ballast lights with LED lights on existing 40' poles.	24	\$790	\$18,960
6.0	Electrical panel & circuit breaker upgrade	1	\$5,000	\$5,000
7.0	Adjust lights for full coverage of tennis courts	24	\$125	\$3,000

Notes: Two poles have new wire and LED lights installed. Recommend using the same lights that were installed.

TOTAL: \$46,250.00

Pole Replacement if needed at additional cost of \$10,000 a pole.



X. EVALUATION CRITERIA

Quotes will be evaluated on the following criteria, not necessarily in order of priority:

- Cost. The cost is reasonable for the effort proposed, is of sufficient detail to explain the cost drivers, and sufficient mechanisms are in place to control costs through the project.
- Experience. The bidder shows relevant experience on similar projects, preferably for similar types/sizes of entities (water districts/utilities, city/local governments, or corporate entities). References will be checked, and results will be incorporated here.
- Approach. The bidder understands and will use appropriate tools, methods, and other approaches to ensure the quality and timeliness of the implementation(s). The use of the latest technologies will be considered as will acceptance of requirements for the project.

SIGNATURE SHEET

My signature certifies that this quote as submitted complies with all terms and conditions as set forth in RFP.

My signature also certifies that this firm has no business or personal relationships with any other companies or persons that could be considered a conflict of interest or potential conflict of interest to FEATHER RIVER RECREATION AND PARK DISTRICT, pertaining to all work or services to be performed because of this request and any resulting contract with FEATHER RIVER RECREATION AND PARK DISTRICT.

I also certify that I have read and understand the terms and conditions in the sample AGREEMENT FOR GENERAL SERVICES, and that any questions regarding such terms and conditions will be addressed during the period allotted for questions.

I hereby certify that I am authorized to sign as a Representative for the Firm:

Name of Firm: Paine Construction Inc.

Address: 7212 8th ST Rio Linda, CA 95673

Fed ID No.: 82-5357420

Name (type/print): Mark Zaychenko

Title: Secretary

Signature: 

Telephone: 916-868-1083

Date: 09/22/2023

To receive consideration for the award, this signature sheet must be fully completed and returned to the Administrative Services Division, as part of your response to this RFP.

Please see page 3 for electronic and physical addresses for the District's Administrative Services Division

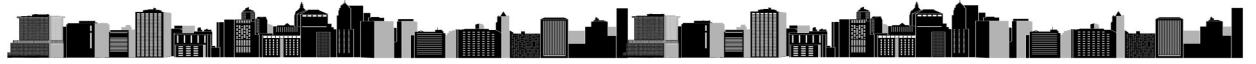

SACTOWN CONTRACTORS

COVER LETTER

Date: 09/22/2023

**FEATHER RIVER RECREATION AND PARK DISTRICT
1875 FEATHER RIVER BLVD OROVILLE, CA 95965**

Please find enclosed Base Bid Proposal for Bedrock Tennis Court Lighting Upgrade (only for LED lighting upgrade) in the amount of Fifty-three thousand two hundred and nine dollars and 00 cents **(\$53,209.00)**.

Please find enclosed Alternative Bid Proposal for Bedrock Tennis Court Lighting Upgrade (for light poles and lighting upgrade) in the amount of One hundred sixty-one thousand eight hundred seventy-seven dollars and 00 cents **(\$161,877.00)**.

SacTown Contractors Corp. solely and responsibly binds itself and its employees to the terms and conditions of the bid. Our bids will be valid for a period of not less than 90 days from the closing date for the receipt of all proposals.

I, Iryna Peravoznikava, have read the entire request in the proposal documents and understand the services that are requested for the job.

Iryna Peravoznikava
President

DIR Registration Number PW-LR-1001065656
License Number 1050461
EIN: 83-3097412



SACTOWN CONTRACTORS

A5

BASE BID PROPOSAL (Only Tennis Courts Lighting Upgrade)

PROJECT TITLE: Bedrock Tennis Courts Lighting Upgrade
OPENING DATE: September 22, 2023
OPENING TIME: 3.00 PM

Unit	Description	QTY	Price	Total	Notes
1	Light pole inspection, evaluation, and determination of condition. Advise on whether they are good or need replaced.	9	\$156.00	\$1,404.00	
2	Electrical wire replacement on pole	9	\$978.00	\$8,802.00	
3	Conduit inspection on all poles, replacement if needed	9	\$296.00	\$2,664.00	
4	Inspect light mounts, replace as necessary	24	\$184.00	\$4,416.00	
5	Replace 24 fluorescent ballast lights with LED lights on existing 40' poles	24	\$555.00	\$13,320.00	Photometrics Design and Lighting Audit
6	Electrical panel & circuit breaker upgrade	1	\$18,835.00	\$18,835.00	ETA 6 weeks
7	Adjust lights for full coverage of tennis courts	24	\$157.00	\$3,768.00	

Total: \$53, 209.00

(Fifty-three thousand two hundred and nine dollars and 00 cents)

Bidder has examined and carefully studied the Bidding documents and other related data identified in the Bidding Documents and the following Addenda, receipt of which is hereby acknowledged.

ADDENDA

No. 1 Date 09/08/2023 Signed 
 No. _____ Date _____ Signed _____

Iryna Peravoznikava
President





SACTOWN CONTRACTORS

A6

ALTERNATIVE BID PROPOSAL (Tennis Courts Lighting and Light Poles Upgrade)

PROJECT TITLE: Bedrock Tennis Courts Lighting Upgrade
OPENING DATE: September 22, 2023
OPENING TIME: 3.00 PM

Unit	Description	QTY	Price	Total	Notes
1	Install new light poles	13	\$8,708.00	\$113,204.00	ETA 6 weeks
2	Install new LED lights	47	\$555.00	\$26,085.00	Photometrics Design and Lighting Audit
3	Electrical panel & circuit breaker upgrade	1	\$17,860.00	\$17,860.00	ETA 6 weeks
4	Adjust lights for full coverage of tennis courts	24	\$197.00	\$4,728.00	

Total: \$ 161,877.00

(One hundred sixty-one thousand eight hundred seventy-seven dollars and 00 cents)

Bidder has examined and carefully studied the Bidding documents and other related data identified in the Bidding Documents and the following Addenda, receipt of which is hereby acknowledged.

ADDENDA

No. 1 Date 09/08/2023 Signed 
 No. _____ Date _____ Signed _____

Iryna Peravoznikava
President





SACTOWN CONTRACTORS

A7

PROJECT DELIVERABLES

We are thrilled to present our Base BID Proposal to provide you with **LED Area light 300W 5000K** slip fitters by LED Mester Inc for your tennis courts. Please find attached the detailed specifications of the product.

One of the key highlights of our proposal is that we offer a **10-year warranty for our LED lights**, ensuring their long-lasting performance and your peace of mind.

In addition to supplying the LED lights, our offering extends beyond tangible products. We strive to provide a comprehensive package of services to meet your specific needs. As part of our Alternative BID Proposal, we also provide replacement options for the existing 40ft light poles with our high-quality products by LED Mester Inc. You can find the detailed specifications for these replacement light poles in the attached documentation.

Firstly, our team will prepare a **detailed photometric design** and **aiming diagram** for each tennis court. This will ensure that the lighting is optimized, providing excellent visibility and enhancing the overall playing experience.

Furthermore, once the lights are installed, we will conduct a **lighting audit** for your reference and records. This audit will serve as a verification of the lighting system's effectiveness and will demonstrate our commitment to providing high-quality lighting solutions.

In addition to the lighting services, we would also like to offer an upgrade to your electrical panels. Our team will design and adopt a custom solution for each court, ensuring that the electrical infrastructure is optimized for the new lighting system. This upgrade will not only improve performance and efficiency but also ensure safety and compliance with industry standards.

We understand the importance of tailor-made solutions, and our team is dedicated to providing exceptional customer service throughout the process. We will work closely with you to understand your specific requirements and deliver a solution that meets and exceeds your expectations.

We look forward to the opportunity to serve you and provide you with top-notch lighting and electrical services for your tennis courts.

Iryna Peravoznikava
President

PROJECT MANAGEMENT APPROACH

1. Project Planning:

- Develop a detailed project plan, including a schedule of activities, resource allocation, and photometrics design.

2. Communication and Reporting:

- Maintain regular communication with the customer through meetings, progress updates, and email correspondence.
- Provide periodic reports on project milestones and any challenges or modifications to the initial plan.
- Respond promptly to any client inquiries, concerns, or change requests.

3. LED Lighting Installation:

- Coordinate the installation of LED fixtures in accordance with photometrics design and aiming diagram.
- Conduct rigorous quality checks during and after installation to ensure proper functioning and optimal lighting performance.
- Keep the customer informed of the installation progress and any potential disruptions or adjustments.

4. Testing and Verification:

- Perform comprehensive lighting audit and verification of the LED lighting system to ensure compliance with regulatory standards, energy efficiency targets, and client expectations.

5. Handover:

- Complete all documentation, such as-built drawings, warranty information, and user manuals.
- Obtain customer sign-off on project completion and hand over the LED lighting system.

6. Project Closure and Support:

- Conduct a final walkthrough with the customer to address any remaining concerns or questions.
- Request customer feedback to assess their satisfaction with the lighting upgrade and overall engagement.

Iryna Peravoznikava
President



SACTOWN CONTRACTORS

A9

REFERENCES

Please find recent project information and contacts as requested.

CITY OF NEVADA CITY

PIONER PARK TENNIS COURT LIGHTING

Project consisted of all demolition, disposal, trenching for the provision and installation of a new 6-pole lighting system for Tennis Court.

COMPLETED: June 2022

CONTACT: Bryan McAlister, PE, PLS City Engineer (530) 265-2496 x126 cell (530) 559-1326
Bryan.McAlister@nevadacityca.gov

CITY OF PACIFICA

TERRA NOVA HIGH SCHOOL TENNIS COURT LIGHTS

LED REPLACEMENT PROJECT

Project consisted of replacing 32 HID Lights to LED Sport Lights

COMPLETED: December 2021

CONTACT: Raymund Donguines (650) 738-3768 rdonguines@pacificca.gov

CITY OF MOUNTAIN VIEW, MOUNTAIN VIEW CA

MOUNTAIN VIEW TENNIS COURTS LIGHTING UPGRADE

Project consisted of replacing 186 HID Lights to LED Area Lights

COMPLETED: August 2020

CONTACT: Kim Truong (650) 903-6290 kim.truong@mountainview.gov
Dale Adams (650) 280-4399 dale.adams@mountainview.gov

FULTON EL CAMINO REC&PARK DISTRICT, SACRAMENTO CA

BALL FILED LIGHTING UPGRADE

Project consisted of installing 64-300W Area Lights at tennis and basketball courts and 54 350W Area Lights at the softball fields

COMPLETED: January 2020

CONTACT: Michael Grace (916) 927-3801 mgrace@fecrpd.com

SUNRISE REC&PARK DISTRICT

RUSH PARK PICKLEBALL LIGHTING UPGRADE

Project consisted of upgrading 20-300W Flood Lights

COMPLETED: February 2020

CONTACT: Jake Polito (916) 725-6287 jpolito@sunriseparks.com



SACTOWN CONTRACTORS

A10

PROJECT TEAM STAFFING AND COMPANY OVERVIEW

Sactown Contractors Corporation DBA Sactown Construction Pros - a lighting solutions provider, established in January 2019 in the greater Sacramento area.

At Sactown Contractors Corp., our unwavering focus has been on delivering exceptional lighting solutions for commercial and industrial sectors. With a dedicated team consisting of two co-owners, Iryna Peravoznikava and Siarhei Karniushka, alongside our skilled workforce of seven employees, we are fully equipped to handle your lighting needs.

Over the years, we have proudly completed numerous successful projects for esteemed clients like SMUD, PG&E, and REDWOOD COAST ENERGY AUTHORITY. Our expertise spans a wide variety of applications, including indoor lighting with new fixture replacements and retrofitting, as well as outdoor lighting for sports facilities like tennis courts, soccer fields, and little league fields. Additionally, we specialize in implementing various lighting controls to enhance energy efficiency and convenience.

One aspect that sets us apart is our commitment to offering only the highest quality products. We proudly provide UL, Energy Star, and DLC/DLC Premium certified lighting solutions, accompanied by an impressive warranty of up to 10 years for products and 1 year for labor. This guarantees your peace of mind and underscores our steadfast belief in both the reliability of our products and the top-notch service we provide.

With our significant experience of over 15 years in the lighting industry, we stand confidently behind every aspect of our work. Our team's knowledge and expertise enable us to tackle projects of any size, complexity, or sophistication. We pride ourselves on delivering exceptional results that exceed expectations, no matter the scope of the project.

We understand that each customer's lighting requirements are unique, and we are dedicated to offering tailored solutions that align with their specific needs. Our team is committed to maintaining effective communication throughout the entire process, ensuring that all project aspects are thoroughly understood and executed to the highest standards.

I would like to affirm that, to the best of our knowledge, no employees who will be actively involved in this engagement have ever been convicted of a felony.

EIN#:83-3097412

License# 1050461 C-10, B. Exp 2/2025

DIR# PW-LR-1001065656 Exp 6/2024

CA SMALL BUSINESS CERTIFIED # 2020446

Iryna Peravoznikava
President



SACTOWN CONTRACTORS CORP
4945 CHELSEA GLEN CT ANTELOPE CA 95843
(530) 786-4583 INFO.SACTOWNCONTRACTORS@GMAIL.COM



SACTOWN CONTRACTORS A11

SIGNATURE SHEET

My signature certifies that this quote as submitted complies with all terms and conditions as set forth in RFP.

My signature also certifies that this firm has no business or personal relationships with any other companies or persons that could be considered a conflict of interest or potential conflict of interest to FEATHER RIVER RECREATION AND PARK DISTRICT, pertaining to all work or services to be performed because of this request and any resulting contract with FEATHER RIVER RECREATION AND PARK DISTRICT.

I also certify that I have read and understand the terms and conditions in the sample AGREEMENT FOR GENERAL SERVICES, and that any questions regarding such terms and conditions will be addressed during the period allotted for questions.

I hereby certify that I am authorized to sign as a Representative for the Firm:

Name of Firm: SACTOWN CONTRACTORS CORP

Address: 4945 CHELSEA GLEN CT, ANTELOPE, CA, 95843

Fed ID No.: 83-3097412

Name (type/print): IRYNA PERAVOZNIKAVA

Title: PRESIDENT

Signature: 

Telephone: (530) 786-4583

Date: 09/08/2023



RFP ADDENDUM #1
Date of Addendum:09/08/2023

NOTICE TO ALL POTENTIAL RESPONDENTS

The Request for Proposals (RFP) is modified as set forth in this Addendum. The original RFP Documents and any previously issued addenda remain in full force and effect, except as modified by this Addendum, which is hereby made part of the RFP. Respondent shall take this Addendum into consideration when preparing and submitting its Proposal.

PROPOSAL SUBMITTAL DEADLINE

The Proposal submittal deadline has been changed as noted herein, and modifies the deadline stated in the RFP. The new Proposal submittal deadline is **3:00 pm** on **September 22, 2023**

1.0 – RFP

Item	Section	Description of Change
1.1	Site Electrical Plans Included	Including Site Electrical Plans not previously included.

2.0 – INFORMATION

The following item(s) are provided as a matter of information only to all respondents and do not modify or become part of the Contract Documents.

Item	Description
1.1	Attached to this Addendum is the site electrical plans for Bedrock Tennis Court.

END OF ADDENDUM

A13

Specifications

Construction:

- The rugged, one-piece die-cast aluminum housing features a complete heat sink that optimizes heat dissipation through convection cooling management.
- Low profile, 3G vibration rated compact design minimizes wind load requirements.
- Housing is completely sealed against moisture and environmental contaminants.

Optics:

- Available in IES Type II, III, IV, V distributions
- Light engines are available in adjustable color temperature (3000K&4000K&5000K) configurations.
- Scalable Lumen Packages from 6,600 to 61,000 Lumens replaces up to 1000W Metal Halide.
- Optics is precisely designed to shape the distribution, maximizing efficiency and application spacing.
- The optics can conform to dark sky requirement.

Electrical:

- Universal 120-277 VAC or 347-480 VAC input voltage
- 10KA(@120-277V) or 20KA(@347-480V) surge protection
- Standard with 0-10V dimming driver
- Power adjustable: 100%, 80%, 60%, 40%.
- THD: ≤20%
- Power Factor: ≥90%

Controls:

- Optional Occupancy sensor or Microwave sensor.
- Optional Bluetooth sensor or Bluetooth controller.
- Optional NEMA 3-pin photocell or 7-pin photocell.

Ambient Temperature:

- Ambient operating temperature -40°C to 45°C (-40°F to 113°F).
- The ambient temperature of 400W is: -40°C to 40°C.

Installation:

- Suitable for mounting heights ranging from 26-50' in area lighting applications
- Round pole, Square pole, slipfitter, wall mount and yoke are available.
- The design can be operated by one person to install the whole lamp

Lifespan:

- Estimated 100,000-hour LED lifespan based on IES LM-80 results and TM-21 calculations

Finish:

- It's available in black or optional dark bronze, silvery gray or white.



Medium Size: 100W/140W/180W



Large Size: 250W/300W/400W



Certifications:

- UL wet location listed
- DesignLights Consortium™ Qualified.
Note: DesignLights Consortium™ Qualified and classified for DLC Premium, refer to www.designlights.org for details.

Note:

Actual performance may differ as a result of end-user environment and application. All values are design or typical values, measured under laboratory conditions at 25°C (±5°C) specifications subject to change without notice.

Structural Design

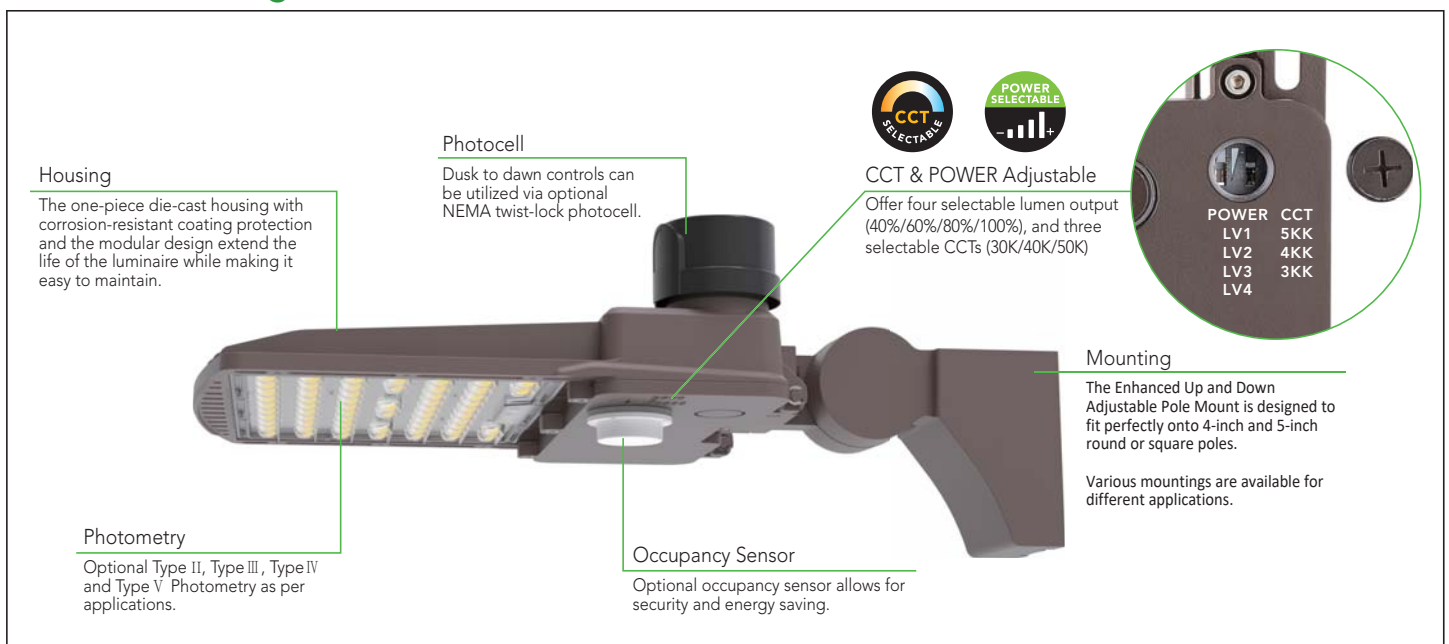

Housing
The one-piece die-cast housing with corrosion-resistant coating protection and the modular design extend the life of the luminaire while making it easy to maintain.

Photometry
Optional Type II, Type III, Type IV and Type V Photometry as per applications.

Photocell
Dusk to dawn controls can be utilized via optional NEMA twist-lock photocell.

CCT & POWER Adjustable
Offer four selectable lumen output (40%/60%/80%/100%), and three selectable CCTs (30K/40K/50K)

Mounting
The Enhanced Up and Down Adjustable Pole Mount is designed to fit perfectly onto 4-inch and 5-inch round or square poles.
Various mountings are available for different applications.

Occupancy Sensor
Optional occupancy sensor allows for security and energy saving.

MAL08100W									
SETTING	SYSTEM WATTS	DIST.TYPE	CRI	3000K		4000K		5000K	
				LUMENS	LPW	LUMENS	LPW	LUMENS	LPW
100%	100W	2	70	14500lm	145 lm/W	15800lm	158 lm/W	15000lm	150 lm/W
		3	70	14500lm	145 lm/W	15800lm	158 lm/W	15000lm	150 lm/W
		4	70	14500lm	145 lm/W	15800lm	158 lm/W	15000lm	150 lm/W
		5	70	15100lm	151 lm/W	16000lm	160 lm/W	15600lm	156 lm/W
80%	80W	2	70	12000lm	150 lm/W	13000lm	163 lm/W	12500lm	156 lm/W
		3	70	12000lm	150 lm/W	13000lm	163 lm/W	12500lm	156 lm/W
		4	70	12000lm	150 lm/W	13000lm	163 lm/W	12500lm	156 lm/W
		5	70	12500lm	156 lm/W	13300lm	166 lm/W	12800lm	160 lm/W
60%	60W	2	70	9300lm	155 lm/W	10000lm	167 lm/W	9600lm	160 lm/W
		3	70	9300lm	155 lm/W	10000lm	167 lm/W	9600lm	160 lm/W
		4	70	9300lm	155 lm/W	10000lm	167 lm/W	9600lm	160 lm/W
		5	70	9600lm	160 lm/W	10200lm	170 lm/W	9850lm	164 lm/W
40%	40W	2	70	6400lm	160 lm/W	6800lm	170 lm/W	6560lm	164 lm/W
		3	70	6400lm	160 lm/W	6800lm	170 lm/W	6560lm	164 lm/W
		4	70	6400lm	160 lm/W	6800lm	170 lm/W	6560lm	164 lm/W
		5	70	6560lm	164 lm/W	7000lm	175 lm/W	6700lm	168 lm/W

MAL08140W									
SETTING	SYSTEM WATTS	DIST.TYPE	CRI	3000K		4000K		5000K	
				LUMENS	LPW	LUMENS	LPW	LUMENS	LPW
100%	140W	2	70	20000lm	147 lm/W	23000lm	164 lm/W	21000lm	150 lm/W
		3	70	20000lm	147 lm/W	23000lm	164 lm/W	21000lm	150 lm/W
		4	70	20000lm	147 lm/W	23000lm	164 lm/W	21000lm	150 lm/W
		5	70	21000lm	150 lm/W	23500lm	168 lm/W	21500lm	154 lm/W
80%	120W	2	70	18000lm	150 lm/W	20000lm	167 lm/W	18500lm	154 lm/W
		3	70	18000lm	150 lm/W	20000lm	167 lm/W	18500lm	154 lm/W
		4	70	18000lm	150 lm/W	20000lm	167 lm/W	18500lm	154 lm/W
		5	70	18500lm	154 lm/W	20500lm	171 lm/W	19000lm	158 lm/W
60%	90W	2	70	13800lm	153 lm/W	15200lm	169 lm/W	14200lm	158 lm/W
		3	70	13800lm	153 lm/W	15200lm	169 lm/W	14200lm	158 lm/W
		4	70	13800lm	153 lm/W	15200lm	169 lm/W	14200lm	158 lm/W
		5	70	14000lm	156 lm/W	15600lm	172 lm/W	14500lm	161 lm/W
40%	60W	2	70	9400lm	157 lm/W	10300lm	172 lm/W	9700lm	162 lm/W
		3	70	9400lm	157 lm/W	10300lm	172 lm/W	9700lm	162 lm/W
		4	70	9400lm	157 lm/W	10300lm	172 lm/W	9700lm	162 lm/W
		5	70	9600lm	160 lm/W	10500lm	175 lm/W	10000lm	167 lm/W

MAL08180W									
SETTING	SYSTEM WATTS	DIST.TYPE	CRI	3000K		4000K		5000K	
				LUMENS	LPW	LUMENS	LPW	LUMENS	LPW
100%	180W	2	70	24800lm	138 lm/W	27000lm	150 lm/W	25200lm	140 lm/W
		3	70	24800lm	138 lm/W	27000lm	150 lm/W	25200lm	140 lm/W
		4	70	24800lm	138 lm/W	27000lm	150 lm/W	25200lm	140 lm/W
		5	70	25500lm	142 lm/W	28000lm	156 lm/W	26000lm	144 lm/W
80%	144W	2	70	20200lm	140 lm/W	22000lm	153 lm/W	20600lm	143 lm/W
		3	70	20200lm	140 lm/W	22000lm	153 lm/W	20600lm	143 lm/W
		4	70	20200lm	140 lm/W	22000lm	153 lm/W	20600lm	143 lm/W
		5	70	20800lm	144 lm/W	22800lm	158 lm/W	21000lm	146 lm/W
60%	108W	2	70	15300lm	142 lm/W	16800lm	156 lm/W	15700lm	145 lm/W
		3	70	15300lm	142 lm/W	16800lm	156 lm/W	15700lm	145 lm/W
		4	70	15300lm	142 lm/W	16800lm	156 lm/W	15700lm	145 lm/W
		5	70	15800lm	146 lm/W	17300lm	160 lm/W	16200lm	150 lm/W
40%	72W	2	70	10500lm	146 lm/W	11500lm	160 lm/W	10800lm	150 lm/W
		3	70	10500lm	146 lm/W	11500lm	160 lm/W	10800lm	150 lm/W
		4	70	10500lm	146 lm/W	11500lm	160 lm/W	10800lm	150 lm/W
		5	70	10800lm	150 lm/W	11800lm	164 lm/W	11000lm	153 lm/W

MAL08250W									
SETTING	SYSTEM WATTS	DIST.TYPE	CRI	3000K		4000K		5000K	
				LUMENS	LPW	LUMENS	LPW	LUMENS	LPW
100%	250W	2	70	33500lm	134 lm/W	37000lm	148 lm/W	34500lm	138 lm/W
		3	70	33500lm	134 lm/W	37000lm	148 lm/W	34500lm	138 lm/W
		4	70	33500lm	134 lm/W	37000lm	148 lm/W	34500lm	138 lm/W
		5	70	34500lm	138 lm/W	38000lm	152 lm/W	35500lm	142 lm/W
80%	200W	2	70	27500lm	138 lm/W	30400lm	152 lm/W	28400lm	142 lm/W
		3	70	27500lm	138 lm/W	30400lm	152 lm/W	28400lm	142 lm/W
		4	70	27500lm	138 lm/W	30400lm	152 lm/W	28400lm	142 lm/W
		5	70	28000lm	140 lm/W	31000lm	155 lm/W	28800lm	144 lm/W
60%	150W	2	70	21300lm	142 lm/W	23200lm	155 lm/W	21800lm	145 lm/W
		3	70	21300lm	142 lm/W	23200lm	155 lm/W	21800lm	145 lm/W
		4	70	21300lm	142 lm/W	23200lm	155 lm/W	21800lm	145 lm/W
		5	70	21800lm	145 lm/W	23800lm	159 lm/W	22500lm	150 lm/W
40%	100W	2	70	14500lm	145 lm/W	16000lm	160 lm/W	14800lm	148 lm/W
		3	70	14500lm	145 lm/W	16000lm	160 lm/W	14800lm	148 lm/W
		4	70	14500lm	145 lm/W	16000lm	160 lm/W	14800lm	148 lm/W
		5	70	15000lm	150 lm/W	16500lm	165 lm/W	15500lm	155 lm/W

MAL08300W									
SETTING	SYSTEM WATTS	DIST.TYPE	CRI	3000K		4000K		5000K	
				LUMENS	LPW	LUMENS	LPW	LUMENS	LPW
100%	300W	2	70	41000lm	137 lm/W	45000lm	150 lm/W	42000lm	140 lm/W
		3	70	41000lm	137 lm/W	45000lm	150 lm/W	42000lm	140 lm/W
		4	70	41000lm	137 lm/W	45000lm	150 lm/W	42000lm	140 lm/W
		5	70	42500lm	142 lm/W	46000lm	153 lm/W	43500lm	145 lm/W
80%	240W	2	70	33600lm	140 lm/W	37000lm	154 lm/W	34500lm	144 lm/W
		3	70	33600lm	140 lm/W	37000lm	154 lm/W	34500lm	144 lm/W
		4	70	33600lm	140 lm/W	37000lm	154 lm/W	34500lm	144 lm/W
		5	70	34500lm	144 lm/W	38000lm	158 lm/W	35500lm	148 lm/W
60%	180W	2	70	26000lm	144 lm/W	28600lm	159 lm/W	26600lm	148 lm/W
		3	70	26000lm	144 lm/W	28600lm	159 lm/W	26600lm	148 lm/W
		4	70	26000lm	144 lm/W	28600lm	159 lm/W	26600lm	148 lm/W
		5	70	26600lm	148 lm/W	29700lm	165 lm/W	27500lm	153 lm/W
40%	120W	2	70	18000lm	150 lm/W	20000lm	167 lm/W	18500lm	154 lm/W
		3	70	18000lm	150 lm/W	20000lm	167 lm/W	18500lm	154 lm/W
		4	70	18000lm	150 lm/W	20000lm	167 lm/W	18500lm	154 lm/W
		5	70	18500lm	154 lm/W	20800lm	173 lm/W	19000lm	158 lm/W

MAL08400W							
SETTING	SYSTEM WATTS	DIST.TYPE	CRI	4000K		5000K	
				LUMENS	LPW	LUMENS	LPW
100%	400W	2	70	60500lm	151 lm/W	60000lm	150 lm/W
		3	70	60500lm	151 lm/W	60000lm	150 lm/W
		4	70	60500lm	151 lm/W	60000lm	150 lm/W
		5	70	61000lm	153 lm/W	60800lm	152 lm/W
80%	320W	2	70	49000lm	153 lm/W	48600lm	152 lm/W
		3	70	49000lm	153 lm/W	48600lm	152 lm/W
		4	70	49000lm	153 lm/W	48600lm	152 lm/W
		5	70	50000lm	156 lm/W	49500lm	155 lm/W
60%	240W	2	70	37600lm	157 lm/W	37200lm	155 lm/W
		3	70	37600lm	157 lm/W	37200lm	155 lm/W
		4	70	37600lm	157 lm/W	37200lm	155 lm/W
		5	70	38500lm	160 lm/W	37600lm	157 lm/W
40%	160W	2	70	26000lm	163 lm/W	25600lm	160 lm/W
		3	70	26000lm	163 lm/W	25600lm	160 lm/W
		4	70	26000lm	163 lm/W	25600lm	160 lm/W
		5	70	26500lm	166 lm/W	26000lm	163 lm/W

SYSTEM WATTS	VOLTAGE	DIST.TYPE	B	U	G
100W	120-277V/347-480V	2	3	0	3
		3	3	0	3
		4	3	0	2
		5	4	0	2
140W	120-277V/347-480V	2	3	0	3
		3	3	0	3
		4	3	0	3
		5	4	0	2
180W	120-277V/347-480V	2	4	0	3
		3	3	0	3
		4	3	0	3
		5	4	0	2
250W	120-277V/347-480V	2	4	0	4
		3	4	0	4
		4	4	0	3
		5	5	0	3
300W	120-277V/347-480V	2	5	0	4
		3	4	0	4
		4	4	0	4
		5	5	0	4
400W	120-277V/347-480V	2	5	0	4
		3	5	0	5
		4	5	0	5
		5	5	0	4

ELECTRICAL DATA

Number Of Drivers	Driver Current (mA)	Nominal Power (W)	INPUT VOLTAGE (V)	CURRENT (Amps)
1	850	100	120	0.83
		100	208	0.48
		100	240	0.42
		100	277	0.36
	2520	100	347	0.29
		100	480	0.21
1	1200	140	120	1.17
		140	208	0.67
		140	240	0.58
		140	277	0.51
		140	347	0.40
		140	480	0.29
1	960	180	120	1.50
		180	208	0.87
		180	240	0.75
		180	277	0.65
		180	347	0.52
		180	480	0.38
1	1200	250	120	2.08
		250	208	1.20
		250	240	1.04
		250	277	0.90
		250	347	0.72
		250	480	0.52
1	1500	300	120	2.50
		300	208	1.44
		300	240	1.25
		300	277	1.08
		300	347	0.86
		300	480	0.63
1	1460	400	120	3.33
		400	208	1.92
		400	240	1.67
		400	277	1.44
		400	347	1.15
		400	480	0.83

MOUNTING

- Standard versatile mounting arm accommodates multiple drilling patterns as well as square and round poles
- Optional for cast aluminum slipfitter mounting adapter (Compatible with more MESTER mounting adaptors such as Tenon, suits for various application)

A17

Mounting Options



Arm Mount
(4" and 5" Square and Round poles)
Standard versatile mounting arm is simple to install and can be used with existing poles for retrofit installations.



Slipfitter Mount
An optional cast aluminum mast arm adapter secures fixture head to nominal 2-3/8" O.D. horizontal steel tenon arm.



Wall Mount
Wall Mount is easy to install for direct wall mounting with 1/2" conduit wiring or standard J-box mounting



Yoke Mount
Die-cast aluminum trunnion is easily adapted to many surfaces and allows easy fixture aiming angles.



Adjustable Arm Mount
Standard versatile mounting arm is simple to install and can be used with existing poles for retrofit installations.

Mounting Dimensions

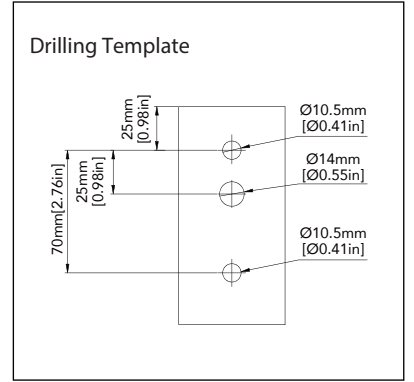
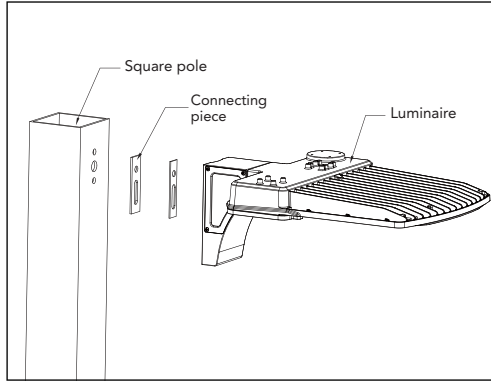
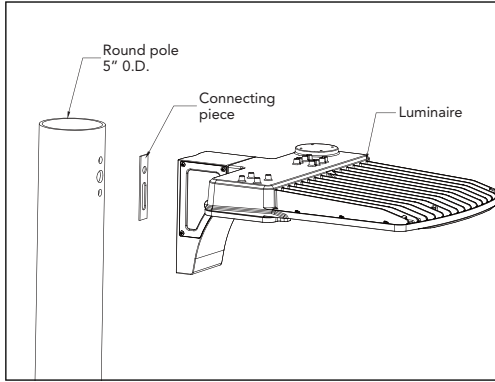

DIMENSION

unit: inch/mm

100W/140W/180W (Adjustable Square Mount)

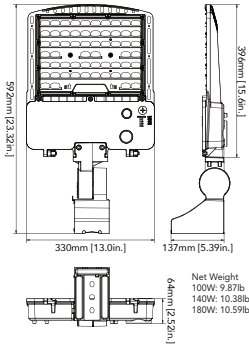

100W/140W/180W (Slipfitter Mount)

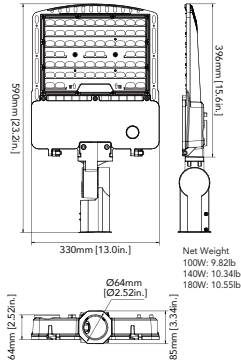

100W/140W/180W (Wall Mount)

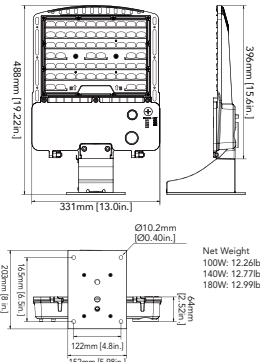

100W/140W/180W (Pole Mount)

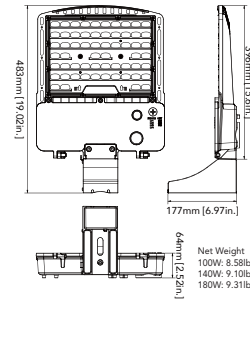

100W/140W/180W (Yoke Mount)

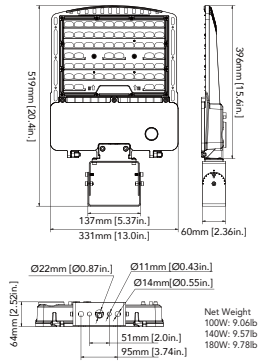

250W/300W/400W (Adjustable Square Mount)

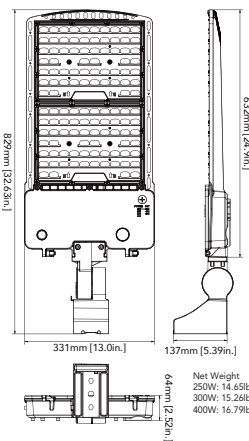

250W/300W/400W (Slipfitter Mount)

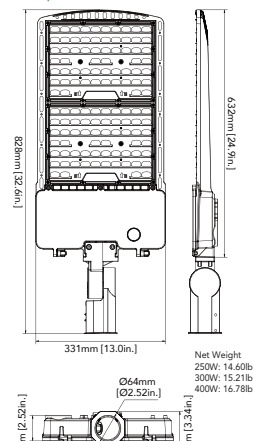

250W/300W/400W (Wall Mount)

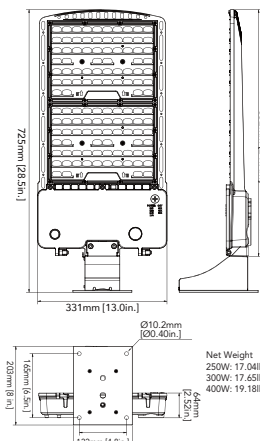



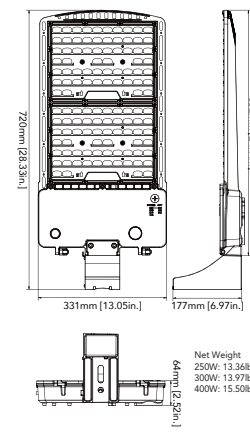

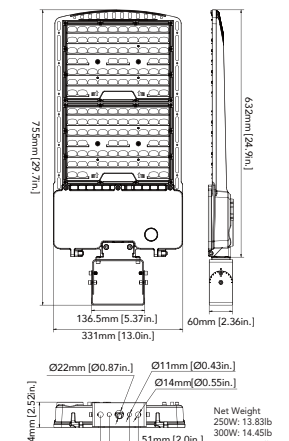

250W/300W/400W (Pole Mount)



250W/300W/400W (Yoke Mount)

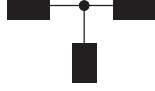
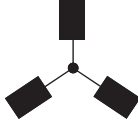

Item							
	1	2 @90°	2 @120°	2@180°	3 @90°	3 @120°	4 @90°
100W/140W/180W	0.3632	0.6849	0.8861	0.7264	1.0481	1.2078	1.0481
250W/300W/400W	0.4758	0.8091	1.059	0.9516	1.2849	1.3923	1.2849

PHOTOMETRICS

Mester offers a complete set of optical systems to meet every site lighting requirement. These systems provide remarkable flexibility in precisely matching light distribution patterns to specific site requirements.

Type 2 optics are ideal for applications where there is a need to space the luminaires farther apart along a road or pathway. The light distribution pattern is optimized for elongated areas, allowing for greater pole spacing without sacrificing lighting quality.

Type 3 optics produce an asymmetrical pattern that directs the majority of the light forward and equally on both sides of the luminaire. In a back-to-back configuration, it creates a rectangular pattern which can extend pole spacings.

Type 4 is suitable for applications where light is primarily required forward with minimal backlight. Typical installations include perimeter poles.

Type 5 optics produce a symmetrical square distribution pattern that distributes light equally on all sides of the luminaire. Type 5 luminaires is universal for most area lighting applications

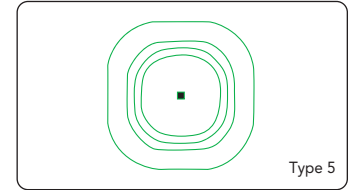
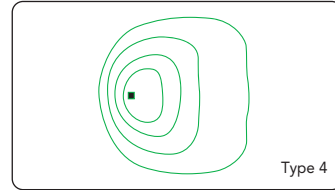
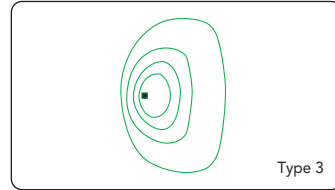
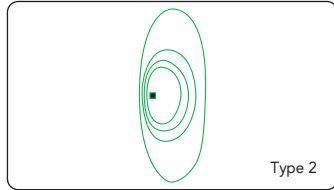

ORDERING GUIDE

Example: MAL08 140W 27V XXK Y Y Y Y Y

Fixture Type	Wattage	Voltage	CCT	Finish	Photocell (Option)	Sensor (Option)	Mounting	Photometry	CCT and Power Adjustable	Internal Code
<input type="checkbox"/>	<input type="checkbox"/>	<input type="checkbox"/>	<input type="checkbox"/>	<input type="checkbox"/>	<input type="checkbox"/>	<input type="checkbox"/>	<input type="checkbox"/>	<input type="checkbox"/>	<input type="checkbox"/>	<input type="checkbox"/>
MAL08 Area Light Series	100 100W 140 140W 180 180W 250 250W 300 300W 400 400W	27V 120-277V 48V 347-480V	DDK1 Adjustable color temperature	D Dark Bronze B Black W White SG Silver Gray	P0 120-277V Photocell P3 347V Photocell P4 480V Photocell Blank Without Photocell	M With Sensor Blank Without Sensor	SQ Square Pole Mount SP Slipfitter Mount WM Wall Mount YK Yoke Mount SQA Adjustable Square Mount	T2 TYPE II T3 TYPE III T4 TYPE IV T5 TYPE V	AD1 With adjustment dial Blank Without adjustment dial	Blank Alphanumeric

Note: Only 400W suit for 4000K, 5000K adjustable and other wattage suit for 3000K, 4000K and 5000K adjustable.

ACCESSORIES(Optional)

AL08 series features a backlight control which provides reduced pixilation and increased visual comfort without compromising performance. External Glare Shield: sold separately or as an accessory.

			
External Glare Shield		External Glare Full Visor	
			
Plug-and-Play PIR Sensor PIR sensor: ANT-6-4T Bluetooth PIR sensor: ANT-6-4T-BLE-SR	Plug-and-Play Microwave Sensor Microwave sensor: ANT-5-4T Bluetooth microwave sensor: ANT-5-4T-BLE-SR	120-277V PIR Sensor PIR sensor: BRI823-B-D Bluetooth PIR sensor: BRI823-B-D-BLE-SR	NEMA Photocell 3 pin NEMA Type: MS-PSUNVB1 3 pin NEMA Type(480V): JL-207F 7 pin NEMA Type: JL-241C
			
Back Light Control Shield			

POLE BRACKET • For mounting one fixture on an existing pole			
	<p>4\" Square Pole Mount with 2-3/8\" O.D. Tenon No. 4SQ-SP-D Finish: Dark Bronze USE: For use with square, non-tapered steel and aluminum poles. Furnished with four 5/16\" hex head stainless-steel bolts. Vertical tenon measures 2-3/8\" O.D., and is made of steel tubing. Fixtures mounted to this bracket can be adjusted both vertically and horizontally.</p>		<p>4\" Round Pole Mount with 2-3/8\" O.D. Tenon NO. 4SQR-SP-D Finish: Dark Bronze USE: For use with Round, non-tapered steel and aluminum poles. Furnished with three 3/8\" hex head stainless-steel bolts. Vertical tenon measures 2-3/8\" O.D., and is made of steel tubing. Fixtures mounted to this bracket can be adjusted both vertically and horizontally.</p>
	<p>5\" Square Pole Mount with 2-3/8\" O.D. Tenon No. 5SQ-SP-D Finish: Dark Bronze USE: For use with square, non-tapered steel and aluminum poles. Furnished with four 5/16\" hex head stainless-steel bolts. Vertical tenon measures 2-3/8\" O.D., and is made of steel tubing. Fixtures mounted to this bracket can be adjusted both vertically and horizontally.</p>		<p>5\" Round Pole Mount with 2-3/8\" O.D. Tenon NO. 5SQR-SP-D Finish: Dark Bronze USE: For use with Round, non-tapered steel and aluminum poles. Furnished with three 3/8\" hex head stainless-steel bolts. Vertical tenon measures 2-3/8\" O.D., and is made of steel tubing. Fixtures mounted to this bracket can be adjusted both vertically and horizontally.</p>
	<p>Pole Bracket Accessories - Angle-Adjustment Adapter NO. SQA-ALDA Finish: Dark Bronze USE: Durable brackets are engineered to provide versatile mounting options. These arms are made from rugged die-cast aluminum. They allow optimal positioning of the light fixture to maximize the lighting effectiveness vertically and horizontally.</p>		<p>Pole Bracket accessories - Tenon & Yoke Adaptor NO. SP-TR-D Finish: Dark Bronze USE: The 2-3/8\" OD Tenon Mount Adaptor for Yoke Fixtures is designed to mount MESTER light fixtures that are equipped with a yoke mount onto a 2-3/8\" OD tenon. It may be utilized with the Mester Flood Light Series of light fixtures.</p>
	<p>Horizontal Wall or Square or Round pole mount with 2-3/8\" Tenon Bracket NO. SQ/R-SP-D Finish: Dark Bronze USE: This tenon bracket can be installed onto a wall, square pole, round pole. Provides wiring access and abuilt-in 2-3/8\" O.D. tenon to mount a fixture with our adjustable slipfitter. Suggested 3/8\" diameter bolts for mounting.</p>		
WALL BRACKET • Attaches to any flat surface • Provides wiring access		Mid-Pole tenon Bracket	
	<p>90\" Wall Mount Bracket with 2-3/8\" O.D. Tenon NO. WM-SP-D Finish: Dark Bronze USE: The 90\" wall mount bracket with 2-3/8\" tenon attaches an MESTER floodlight to almost any surface: wall, roof, or wood pole. Provides wiring access and abuilt-in 2-3/8\" O.D. tenon to mount a fixture with our adjustable slipfitter. Suggested 3/8\" diameter bolts for mounting. Mounting holes are spaced 3-1/4\" apart.</p>		<p>2-3/8\" OD Horizontal Tenon Mid-Pole Bracket NO. SQ-SP-D Finish: Dark Bronze USE: 2-3/8\" OD Horizontal Tenon Mid-Pole Bracket is designed to mount light fixture that is equipped with an adjustable slipfitter onto a 2-3/8\" OD horizontal tenon</p>
Round External Mount Horizontal Tenon • To mount 2/3/4 fixtures on a existing pole			
	<p>Double 90\" Horizontal Tenon Adaptor NO. R60-SP2-90-D Finish: Dark Bronze USE: The Bracket is designed to mount over 2-3/8\" (60mm) O.D. vertical tenon. Two fixtures can be mounted to the Round External Mount Horizontal Tenon and adjusted horizontally</p>		<p>Triple 120\" Horizontal Tenon Adaptor NO. R60-SP3-120-D Finish: Dark Bronze USE: The Bracket is designed to mount over 2-3/8\" (60mm) O.D. vertical tenon. Three fixtures can be mounted to the Round External Mount Horizontal Tenon and adjusted horizontally</p>
	<p>Double 180\" Horizontal Tenon Adaptor NO. R60-SP2-180-D Finish: Dark Bronze USE: The Bracket is designed to mount over 2-3/8\" (60mm) O.D. vertical tenon. Two fixtures can be mounted to the Round External Mount Horizontal Tenon and adjusted horizontally</p>		<p>Quad 90\" Horizontal Tenon Adaptor NO. R60-SP4-90-D Finish: Dark Bronze USE: The Bracket is designed to mount over 2-3/8\" (60mm) O.D. vertical tenon. Four fixtures can be mounted to the Round External Mount Horizontal Tenon and adjusted horizontally</p>
	<p>Triple 90\" Horizontal Tenon Adaptor NO. R60-SP3-90-D Finish: Dark Bronze USE: The Bracket is designed to mount over 2-3/8\" (60mm) O.D. vertical tenon. Three fixtures can be mounted to the Round External Mount Horizontal Tenon and adjusted horizontally</p>		

FEATURES & BENEFITS

- **Pole top option:**

Removable plastic top cover (pole is drilled) or welded steel tenon (pole is mortise option) can be supplied on customer's request for fitting light fixtures. The drilling mode shall be provided by the customer, unless the project uses energy lamps; If the mortise and tenon option is selected, the customer needs to determine the appropriate mortise and tenon dimensions for the project.

- **Vertical shaft:**

Hot rolled commercial quality welded steel pipe with a minimum yield strength of 42,000 psi is rugged and can be used to manufacture pole shafts.

- **Handhole:**

The reinforced handhole is located at a 12" base and can be used according to the selected lighting application.

- **Base cover:**

A 2-piece ABS plastic base cover is available, easy to assemble and mount on the pole, and securely attached.

- **Anchor bolts:**

Each bolt includes 2 nuts and 2 washers. The top of the anchor bolt is threaded and can be used to secure and level rods with accompanying nuts and washers.

- **Color and finish options:**

Commercial grade, ultra durable powder coating, hot dip galvanizing process for greater hardness and durability. Powder-coated, hot-dip galvanizing is available as a premium option.

- **Other Options:**

The following options are available: Shock absorber, custom mortise and tenon size, custom color, electric /GFI socket, custom rod height, additional hand holes, UL compliant hand holes and custom base plate size.

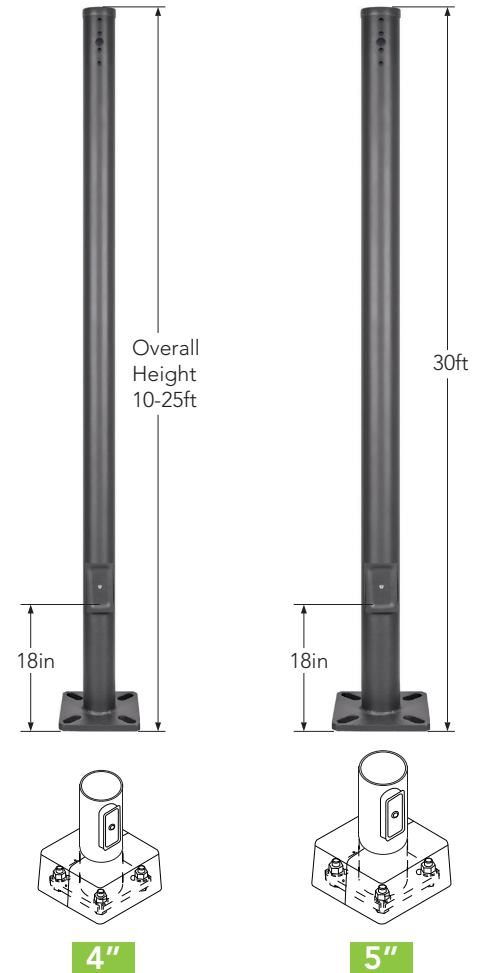

ORDERING INFORMATION

Example: **MRP** — **10FT** — **4IN** — **11G** — **D**

Model	Height	Size	Thickness	Finish
MRP Straight Round Poles	10FT (3.0 M)	4IN (4" Diameter)	7G (7 Gauge)	D Dark Bronze
	15FT (4.6 M)	5IN (5" Diameter)	11G (11 Gauge)	B Black
	20FT (6.1 M)			W White
	25FT (7.6 M)			
	30FT (9.1 M)			

Note: 1. 10-25ft suit for 4in, 11G.

2. 30ft only suit for 5in, 7G, see technical details table for complete ordering information.

TECHNICAL DETAILS

Catalog Number	Shaft Size (in)	Shaft Height (ft)	Wall thick (in)	Gauge	Weight(LBS)	Maximum EPA with 1.3 Gust Factor					
						80 MPH	Max weight	90 mph	Max weight	100 mph	Max weight
MRP-10FT-4IN-11G	4"	10	0.120	11	70	19.1	480	15	370	12.2	300
MRP-15FT-4IN-11G	4"	15	0.120	11	100	9.6	250	7.4	185	5.9	150
MRP-20FT-4IN-11G	4"	20	0.120	11	120	6	150	4.4	150	3.4	125
MRP-25FT-4IN-11G	4"	25	0.120	11	145	2.8	100	1.9	75	1.3	75
MRP-30FT-5IN-7G	5"	30	0.179	7	305	4.2	150	3	125	2.25	100

ANCHORAGE DETAIL

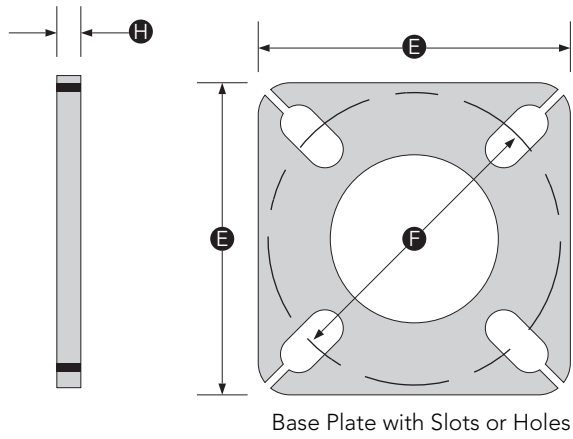

Anchor Base size	Wall thick H	Base Plate Square E	Bolt Circle Range (in)	Bolt Circle F	Bolt Projection
4"	0.75"	10.5"	8-11	9.5"	3.5"
5"	0.75"	11"	10.6-12	11.3"	3.5"

DIMENSIONS

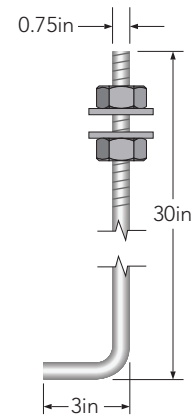
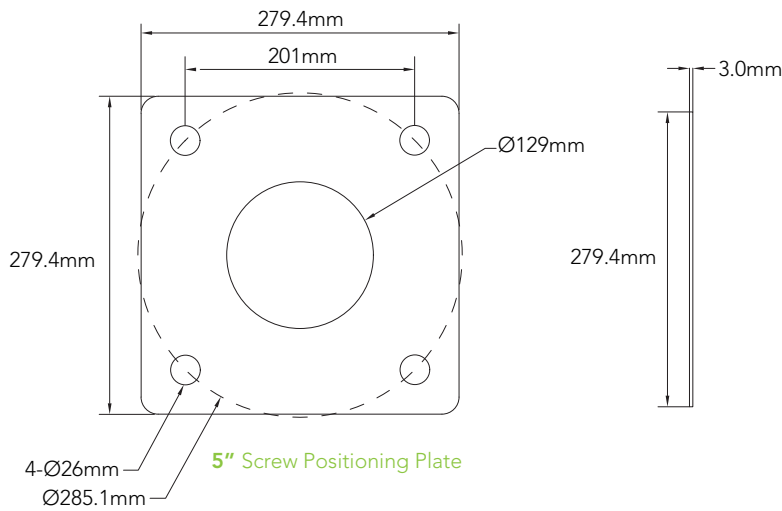
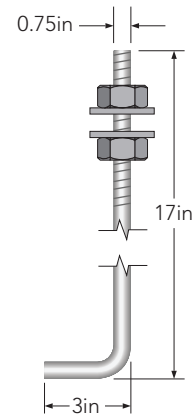
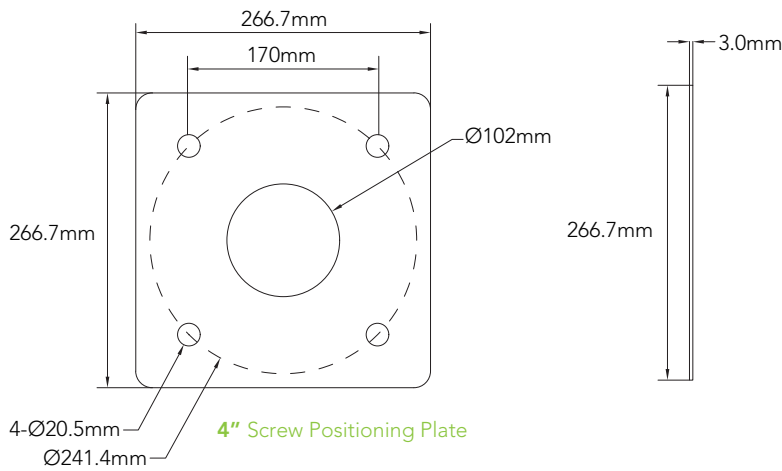

MESTER LED LIMITED

P: +86 755 28173385 Email: sales@szmester.com
 3rd F, Section B, Building A, Sunshine Industrial Park, Hezhou, Xixiang, Bao'an District, Shenzhen China.

Specifications are subject to change without notice.
 Updated date: 2023-07-03



SACTOWN CONTRACTORS

A22

CITY OF MOUNTAIN VIEW
CUESTA TENNIS CENTER & RENGTORFF PARK TENNIS CTS





SACTOWN CONTRACTORS

FULTON - EL CAMINO RECREATION AND PARK DISTRICT
HOWE PARK TENNIS CT





SACTOWN CONTRACTORS

A24

SUNRISE RECREATION AND PARK DISTRICT
RUSH COMMUNITY PARK TENNIS CT



Williams Electric Company

5625 Baggett-marysville rd
Oroville, Ca
CA. Lic#1035132
(530)717-3253
wee.incorporated@gmail.com
williamselectriccompany.com

Sept 7, 2023

To whom it may concern,

Hello

This is Williams Electric Company Licenced with CA Lic#1035132. We are submitting a bid for BedRock Tennis court Lighting. We have attached the bid proposal for your consideration. Please contact us if there are any questions or concerns. Thank you for the opportunity to work with you. It is always a pleasure and we look forward to hearing from you.

Sincerely,

Shannon Williams

President



Williams Electric Company

FRRPD
 Feather River Recreation & Park District
 1150 5th Ave
 Oroville, CA 95965

☎ (562) 440-5754
 ✉ Joev@frrpd.com

CONTACT US

5625 Baggett Marysville Rd
 Oroville, CA 95965

☎ (530) 717-3253
 ✉ wee.incorporated@gmail.com

ESTIMATE	#1031
ESTIMATE DATE	Sep 22, 2023
TOTAL	\$63,250.30

ESTIMATE

Services	qty	unit price	amount
Bedrock Tennis Courts			
Poles 2 lights	6.0	\$4,291.16	\$25,746.96
Poles 2 lights pipe with wire			
Poles 4 lights	3.0	\$8,396.16	\$25,188.48
Poles 4 lights pipe with wire			
New wire	1.0	\$9,873.19	\$9,873.19
Five conductors pulled through every pipe therefore dimmable feature will work			
Electrical Panels & circuit breaker upgrades	1.0	\$18,254.25	\$18,254.25
Electrical Panels & circuit breaker upgrades			

Services subtotal: \$79,062.88

A27

Subtotal	\$79,062.88
multi job	-\$15,812.58
Tax (card 3.5%)	\$0.00
Total	\$63,250.30

We appreciate your business. All payments are due upon receipt. A 10% late fee will be added on 10 days after invoice is delivered and 10% every 30 days after that. We appreciate your prompt payment.

Williams Electric Company | CA
lic#1035132

<http://williamselectriccompany.com>

Park Court Light Automation and Control

Scope:

Provide controls to power light relays on court for specific time allowance

Provide remote scheduling website to feed the light controls at the court

Scheduling Application:

Application will allow a standard calendar view with scheduled blocks. User will be able to select unscheduled block and define hours of use. Standard will be 2 hours (120 minutes)

Entry View:

The screenshot displays a scheduling application interface. A modal window titled "EVENT DETAILS" is open, allowing for the creation or editing of an event. The background shows a calendar grid with a time slot selected for Monday, October 11th, from 9 AM to 3 PM. The event name is "Team Meeting", the start time is "Oct 12, 2021 9:00 AM", and the end time is "Oct 12, 2021 3:00 PM". The event type is set to "Default" and the assignee is "admin". The notes field contains "Monthly team meeting." The interface includes a "TODAY" button, navigation arrows, and a "Logged in: admin" status indicator. The calendar grid shows days from Monday to Friday and times from 8 AM to 6 PM.

Time	MON 11	TUE 12	WED 13	THU 14	FRI 15
8 AM					
9 AM	Team Meeting admin				
10 AM					
11 AM					
12 PM					
1 PM					
2 PM					
3 PM					
4 PM					
5 PM					
6 PM					

Single Day View:

Logged in: admin [↗](#)

TODAY < > October 2021 5-DAY

	MON 4	TUE 5	WED 6	THU 7	FRI 8
8 AM					
9 AM					
10 AM					
11 AM					
12 PM					
1 PM					
2 PM					
3 PM					
4 PM					
5 PM					
6 PM					

Scheduled View:

Logged in: admin [↗](#)

TODAY < > October 2021 5-DAY

	MON 11	TUE 12	WED 13	THU 14	FRI 15
8 AM					
9 AM		Team Meeting admin		Customer Demo admin	
10 AM					
11 AM					
12 PM					
1 PM				Afternoon Review admin	
2 PM					
3 PM					
4 PM					
5 PM					
6 PM					

Controls Required:

4-8 Channel PLC controller with output relays

120V circuit

Cellular WAN Connectivity or Internet connection

Ignition Software (Maker Edition or full Ignition License)



B1

STAFF REPORT

DATE: October 4, 2023

TO: FRRPD Board of Directors

FROM: Chris Wagoner, General Manager

RE: Board Policies and Procedures

SUMMARY

The Board Policies and Procedures Handbook has not been updated since 2015. Should be reviewed annually.

2 Items for review

1. Reviewed and updated some grammatical errors. Track changes are still in attachment.
2. Included statement about on-going board training.

RECOMMENDATION

Approve Policies and Procedures. Will review again next year.

ATTACHMENTS:

Policies and Procedures.

This is a living document and will continue to change and be modified to reflect different circumstances as FRRPD continues to grow.

*Adopted by Resolution 1301-15
December 15, 2015*

TABLE OF CONTENTS

SECTION	TITLE	PAGE
	Definition of Terms _____	4
1	The Nature of Recreation, Parks and Open Space Facilities and Services _____	4
2	Formation _____	5
3	Mission & Vision Statement _____	6
4	Board of Directors _____	7
5	Functions, Duties and Responsibilities of the Board of Directors _____	7
6	Officers of the Board of Directors _____	8
7	Powers of the Board of Directors _____	9
8	Conflict of Interest Code _____	10
9	Regular Meetings of the Board of Directors _____	12
10	Special Meetings of the Board of Directors _____	12
11	Parliamentary Procedure and Rules _____	14
12	Adjournment of Board of Directors Meetings _____	14
13	Quorum _____	14
14	Order of Business for Board of Directors Meetings _____	14
15	Minutes of the Board of Directors Meetings _____	15
16	Disruption of Board Meetings _____	15
17	Board Standing Committees _____	17
18	Functions of the Standing & Ad-Hoc Committees _____	18
19	District Employees _____	19

SECTION	TITLE	PAGE
20	District Budget Presentation _____	21
21	District Finances _____	23
22	District Audit _____	23
23	Purchase Procedure Policy _____	24
24	Petty Cash- Cash Fund	25
25	Procedures for Petty Cash Fund	25
26	Leases, Contracts, etc. _____	26
27	Service Contracts _____	26
28	Surplus Property _____	27
29	Certificates of Appreciation or Recognition _____	31
30	Facility/Program Use and Fees _____	31
31	Injury & Illness Prevention Program _____	33
32	Fixed Assets _____	33
33	Liability & Workers' Compensation Insurance _____	33
34	Security and Retention of Forms Policy _____	34
35	American Disabilities Act _____	35
36	Amendments to the Feather River Recreation and Park District By-Laws _____	35
37	District Map _____	36
ADDENDUM	Rejection of Bids _____	37
APPENDIX	A. Copies of Resolutions	
	B. Record Retention Policy	

DEFINITION OF TERMS

DISTRICT:

The Feather River Recreation and Park District is a non-enterprise, independent, special district in Butte County. The Feather River Recreation and Park District derives its powers and obligations from the State of California Public Resources Code Division 5, Chapter 4, commencing with Section 5780.

DISTRICT OFFICE:

The District Office is located at the Feather River Recreation and Park District, 1875 Feather River Blvd., Oroville, California 95965. Telephone: (530) 533-2011.

EXECUTIVE DIRECTOR:

The Executive Director or Secretary shall be construed to mean the General Manager or the authorized representative.

SECTION 1

THE NATURE OF RECREATION, PARKS, OPEN SPACE FACILITIES & SERVICES

The Feather River Recreation and Park District encompasses an area of 730 square miles in South-eastern Butte County. Although Oroville is the hub of the District and most services are centered there, programs and facilities are also provided in the various rural communities ranging from the valley floor into the mountains. Along with the greater Oroville area, other District communities include Palermo, Bangor, and Honcut in the valley, and the mountain areas of Berry Creek, Feather Falls, Forbestown, Pentz, and Concow. The latter two are served in cooperation with the Paradise Recreation and Park District. Feather River Recreation and Park District facilities include:

1. Bedrock Park Tennis Courts
2. Feather River Bike Trail
3. Playtown USA Park
4. Gary Nolan Sports Complex
5. Martin Luther King Jr. Park and Amphitheater
6. Nelson Sports Complex - including Nelson Pool
7. Palermo Park - including Palermo Pool and Competition Horseshoe Courts
8. Palermo Hall
9. Forbestown Park - including Charles Lynnd's Hall
10. Yuba Sutter Historical Museum
11. Bedrock Skate & Bike Park
12. Riverbend Park
13. Feather River Activity Center
14. Berry Creek Park

SECTION 2

FORMATION

In the early 1950s, a group of forward-thinking residents identified a pressing need for recreational services in Oroville. They recognized that the City of Oroville, due to its charter, lacked the fiscal capabilities to fund the necessary recreational amenities both for that time and the near future. Notably, they acknowledged that Oroville, being a central hub, catered to a broader rural suburban populace who, despite not contributing to City taxes, relied on the city for recreational services.

Understanding this, these visionary citizens concluded that the City required a legitimate means to generate funds which would not only benefit the city but also its neighboring areas. Thus, the idea of the Recreation District was conceived.

Heeding the community's call, a joint resolution was passed on July 30, 1951, by the Butte County Board of Supervisors and the City of Oroville to initiate the formation of a Recreation Park and Parkway District. A public hearing on October 15, 1951, led to this proposal being presented to voters in June 1952. Subsequently, as per the Public Resources Code, the Butte County Board of Supervisors established the FEATHER RIVER RECREATION PARK AND PARKWAY DISTRICT.

By the late 1950s, changes in the Public Resources Code resulted in renaming "Recreation Park and Parkway Districts" to "Recreation and Park Districts". In alignment with this change, on August 25, 1959, the Board of Directors ratified Resolution No. 15, reconstituting the District under the updated provisions of the Public Resources Code. Three days later, the California Secretary of State confirmed the District's reorganization, cementing its status as a Recreation and Park District in Butte County under its new title:

"FEATHER RIVER RECREATION AND PARK DISTRICT."

."

SECTION 3

MISSION, GUIDING PRINCIPLES AND VISION STATEMENT

MISSION:

The Feather River Recreation and Park District will provide and maintain quality parks, recreation experiences and related facilities and programs for all residents of the District in a fiscally sustainable manner that compliments the natural resources and cultural heritage of our community.

GUIDING PRINCIPLES:

The Feather River Recreation and Park District will achieve its mission in an affordable manner that improves the quality of life for all our citizens by:

- Listening to the community
- Fostering community involvement
- Creating active partnerships
- Promoting forward thinking
- Offering regional appeal
- Delivering excellence in services and effective management through internal team- building
- Developing public awareness
- Providing a safe and nurturing environment
- Keeping pace with growth and community needs

VISION STATEMENT:

The Feather River Recreation and Park District will:

- **Maintain**, establish, or integrate a growing and diverse system of parks, recreation facilities and open space areas throughout the District.
- **Promote**, provide, and acquire recreational opportunities along the Feather River Parkway downstream of the Oroville Dam to the County line in cooperation with others.
- **Provide** cultural, historic, interpretive, leisure, recreational, and sports programs.

SECTION 4

BOARD OF DIRECTORS

Pursuant to Public Resources Code Section 5784, the Board of Directors of Feather River Recreation and Park District has five members who serve as the Board of Directors. Board members are elected at large during the general election for a four-year term. There is currently no restriction on the number of consecutive or non-consecutive terms a Board member may serve. The Feather River Recreation and Park District alternates the Board of Directors' terms of office so three Board members' and then two Board members' terms of office expire every two years. Upon being elected, the term of office begins on the first Friday in December of the year elected.

VACANCIES:

Board member vacancies may be filled by the remaining District Board members within 90 days after the vacancy occurs in accordance with provisions of Section 5781.13 of the Public Resources Code.

SECTION 5

FUNCTIONS, DUTIES & RESPONSIBILITIES OF THE BOARD OF DIRECTORS

The main function of the Board of Directors is to set District policy. A policy, as used herein, is a definite course of action adopted by the Board of Directors. It defines what shall be done, what purpose shall be pursued, what principles shall govern, what program shall be followed, what financial procedures shall operate, what the personnel practices shall be, and what course of action shall be taken described and passed by approved motions in minutes, Board resolutions and applicable laws.

Policy **determination** is the responsibility of the Board of Directors alone.

Policy **execution** is the responsibility of the General Manager and other District personnel.

Specific duties of the Board of Directors:

- To perform its legal responsibilities, including the selection of legal counsel
- To set up by-laws, regulations, rules, and operating procedures
- To select, employ, and if necessary, dismiss the General Manager and affirm General Manager's decision for other managerial positions.
- To control the financial plans and procedures of the District
- To establish and control all operating budget funds of the District
- To establish and control liability and workers compensation insurance.
- To cause to care for and maintain property.

- To cause to be responsible for programs
- To assure sound personnel policies
- To maintain good public relations
- To appoint, commission, supervise, and receive reports from committees and the General Manager

BOARD MEMBER RESPONSIBILITIES:

Board members should:

- Understand the significance and importance of recreational programs and park services in the community.
- Be aware of the relationship of recreational programs and park services to other public agencies and community services.
- Look objectively at their specific responsibilities as Board members and at total community recreational and park needs, and keep abreast of the changing conditions, continuously reassessing their efforts and reasons for service.
- Have the courage to resist pressures of all types and insist upon the highest standards for their agency, particularly regarding competent and professional personnel. Each Board member represents the District as a whole and not any one section.
- Attend all meetings assigned and notify the General Manager if unable to attend.
- Be aware of their role as Board members being well informed and up to date on all issues, acting independently and avoiding the pursuit of personal objectives.
- Dedicate oneself to ongoing training with relevant materials to uphold the highest standards of excellence as an FRRPD Board of Director. The Board decision shall be final. Board members will act as a court of appeal for disagreements arising between employees, and between the public and employees, if all other District procedures fail to solve the issue(s). Board members' decision shall be final.

SECTION 6

OFFICERS OF THE BOARD OF DIRECTORS

DISTRICT OFFICE:

The District Officers shall include a Chairperson and Vice-Chairperson and the General Manager shall be the Secretary of the Board. The Board of Directors, at their regularly scheduled Board meeting in December of each year and shall elect officers. Election of officers shall be the first order of business. No officer shall serve for more than two consecutive terms in one office, except that of the Secretary.

DUTIES OF THE CHAIRPERSON:

It shall be the duty of the Chairperson to preside at all meetings of the Board of Directors, appoint committees, call special meetings when they may be deemed advisable, execute all documents, papers, and warrants on behalf of the Board of Directors, and act as the Liaison Officer between the public and the Board when the circumstances warrant. The Chairperson, when acting as the Liaison Officer for the Board, shall carry out the directives,

if any, of the Board. As Chairperson of the Board, he/she is responsible for creating an environment where communication is encouraged and polling each Board member. He/she strives to stimulate discussion among the Board of Directors and team members and to focus attention on the topic of discussion. He/she sees to it that a summary statement is made on what the discussion is all about; that pertinent clarifying data is presented and determines whether a motion is in order. When the discussion has run its course, he/she will attempt to resolve the issue by formal Board action. The Chairperson entertains a motion but does not make a motion. The Chairperson should take an active role in the discussion and is entitled to vote on every issue in the same manner as other Board members. The Chairperson should meet with the General Manager in advance of the Board meeting to review the agenda items.

DUTIES OF THE VICE-CHAIRPERSON:

In the absence or disability of the Chairperson, the Vice-Chairperson shall have all powers to perform the duties of the Chairperson; including the ability to call special meetings of the Board, should the Chairperson refuse to do so. A quorum of the Board shall also have the power to call a special meeting of the Board.

DUTIES OF THE SECRETARY:

The Secretary shall keep, or cause to be kept, full and complete records of the proceedings of the Board of Directors and of its meetings and give, or cause to be given, notice of all regular and special meetings of the Board of Directors as required on behalf of the District. The Secretary of this Board shall also appoint the Clerk of this Board who shall perform all the duties imposed by law upon the Clerk. The Board Clerk is assigned the responsibility to keep minutes for the Board. The Board clerk may also be known as the Executive Administrator.

SECTION 7

POWERS OF THE BOARD OF DIRECTORS

The Board of Directors shall have and may exercise such powers as are bestowed upon it by Public Resources Code Sections 5780, et seq. and any amendments or additions thereto and by all other laws of the State of California. Included among these powers, but not limited to them, are the following:

Make and enforce all regulations, policies, and procedures necessary for the administration and governance of District programs, and for the acquisition, improvement, and maintenance of parks and recreation facilities within the District. It may appoint agents and employees sufficient to maintain and operate the parks and recreation facilities for the benefit of the District, and it may construct all needed structures and perform all other acts necessary to accomplish the purpose of this section.

Remuneration and Expenditure Reimbursement

Purpose. The purpose of this policy is to prescribe the way district employees and Directors may be reimbursed for expenditures related to District business, and how directors may be compensated for their service. (District) shall adhere to Government Code Sections 53232 through 53232.4 when dealing with issues of director remuneration and reimbursement.

Process. To these Bylaws and in accordance with California Public Resources Code Section 5784.15 and Board adopted Resolution 1056-09, Directors shall receive remuneration in the amount of \$100 (one hundred dollars) for attendance at each board or committee meeting, with a maximum compensation of \$200 (two hundred dollars) in any calendar month. Directors shall be compensated on the date of the first payroll of the month following the month of attendance.

Ethics Training

All Directors of the Feather River Recreation and Park District shall receive two hours of training in general ethics principles and ethics laws relevant to public service within one year of election or appointment to the Board of Directors and at least once every two years thereafter, pursuant to Government Code Sections 53234 through 53235.2.

Directors shall obtain proof of participation after completing the ethics training and the District shall retain proof in District records.

SECTION 8

CONFLICT OF INTEREST CODE

All Board members, staff and volunteers will comply with the District's conflict of interest code.

The Political Reform Act, Government Code Sections 81000 et seq., requires state and local government agencies to adopt and promulgate Conflict of Interest Codes. The Fair Political Practices Commission has adopted a resolution, 2 Cal. Code of Regulations Section 18730, that contains the terms of a standard Conflict of Interest Code, can be incorporated by reference and which may be amended by the Fair Political Practices Commission to conform to amendments in the Political Reform Act after public notice and hearings. Therefore, the terms of 2 Cal. Adm. Code Section 18730 and any amendments to it duly adopted by the Fair Political Practices Commission, the following officials and employees are designated, and disclosure categories are defined.

The District has adopted as its conflict-of-Interest Code the model code set forth in 2 Cal Code of Regulations Section 18730. The following persons are designated employees who must file Statements of Economic Interest (Form 700) with disclosure responsibilities as set forth below:

DESIGNATIONS:

The positions of members of the Governing Board, General Manager, management positions and Consultants have been designated as those positions subject to the provisions of the Conflict-of-Interest Code in that those positions are the only positions having any substantial responsibility relative to the Feather River Recreation and Park District decision-making process or policy. Persons in these positions shall file a Statement of Economic Interest with the Butte County Clerk's Office, 25 County Center Drive, Oroville, CA 95965.

DISCLOSURE RESPONSIBILITIES:

The categories relative to the types of interests that must be disclosed are based upon the types of fiscal interests relevant to District business that is confined to providing various recreational services and facilities to the community.

CODE OF ETHICS

Per Board Resolution 965-07, FRRPD has adopted the following standards for members of the Board of Directors in the exercise of the District's Ethics and Compliance Program (hereinafter "Program"):

- A. **Reporting.** Directors must assure themselves that information and reporting systems exist within FRRPD that are reasonably designed to provide upper management and the Board with accurate information sufficient to allow management and the Board, each within its scope, to reach informed judgments concerning both the district's compliance with law and to maximize its business performance. In this regard, it is important that the Board exercise diligence in assuring that appropriate information will come to its attention in a timely manner as a matter of ordinary operations.
- B. **Oversight.** All Board members shall exercise oversight over the operations of the district in a good-faith attempt to monitor its operations. Conscious action by open communications with the District Manager between meetings and during general and special meetings held by FRRPD must be utilized to assure that the district is exercising the proper morals and ethics in its daily operations.
- C. **Personal Accounting for Conflict.** It is of the utmost importance that members of the Board operate morally and with the best interests of the District in mind. In this regard, should the actions of any employee of the District or a Board member be deemed unethical, the remaining Board members have an obligation to bring such conduct to the immediate attention of the Board.

- D. Complaints.** The District shall establish a method for the receipt, retention, and treatment of complaints regarding District operations, as well as the confidential anonymous submission by employees of concerns regarding questionable behavior. The District Manager shall be responsible for establishing such procedures. Reasonable steps must be taken to evaluate such complaints and to determine what action, if any, should be taken in response thereto. No retaliation shall be made against an employee, Board Member or third party complaining about workplace conditions or the unethical or immoral conduct of a co-worker or a member of the Board. This program must be consistently promoted through incentives and enforced through appropriate disciplinary measures.

SECTION 9

REGULAR MEETINGS OF THE BOARD OF DIRECTORS

Per Resolution NO. 1149-14 regular meetings of the Board of Directors shall be held on the fourth Tuesday of each month with open session commencing at 5:30 p.m. at the Feather River Activity Center, 1875 Feather River Blvd., Oroville, California, and are intended to facilitate the business meeting in a timely and efficient manner. However, any other time and place that meets with the approval of most of the Board and is within the District may be designated for a regular meeting of the Board. It shall be the duty of the General Manager and staff to make available an agenda and Board packet to each Director by 5:00 p.m. on the Thursday prior to the Tuesday meeting. However, all business transacted at a regular meeting at which there is a constituted quorum of Directors shall be valid and binding. Should any regularly scheduled meeting fall upon the week of a legal holiday, then said meeting shall be held either the Tuesday before or Tuesday after the scheduled meeting per the Board's recommendation made at a regular board meeting. If the meeting is a regular meeting, i.e., occurs on the body's regular day, without a special meeting call, the agenda must be posted 72 hours in advance (Section 54954.2(a)). All regular meetings must comply with the Ralph M. Brown Act.

A quorum of the Directors may adjourn any Director's meeting to meet again at a stated day and hour; provided, however, that in the absence of a quorum, most of the Directors present at any Directors' meeting, either regular or special, may adjourn the meeting. The Chairperson cannot adjourn the meeting without the consent of the majority. If a majority vote cannot be reached to adjourn a meeting with the absence of a quorum, the meeting will adjourn 30 minutes after the scheduled start of the meeting, at which time the meeting will be rescheduled.

SECTION 10

SPECIAL MEETINGS OF THE BOARD OF DIRECTORS

The Chairperson or most of the Board may call a special meeting at any time, provided it meets all Ralph M. Brown Act requirements. Special meetings should be conducted at the Feather River Activity Center but may be scheduled at another location within the District boundaries if most of the Directors concur. It shall be the General Manager's duty to make available an agenda to each Director a minimum of 24 hours before each special meeting. For special meetings, the call to the meeting and the agenda (which are typically the same) must be posted at least 24 hours in advance (Section 54956).

CLOSED SESSIONS, EXCLUSIONS:

Closed sessions may be conducted by the Board of Directors of the District as permitted under the Ralph M. Brown Act, as set for the in-Government code Sections 54956.7, et seq.

- Matters affecting national and public buildings security.
- The appointment, employment, or dismissal of an employee or to hear complaints or charges brought against such employee by another officer, person, or employee unless such officer or employee requests a public hearing. Said body also may be excluded from any such public or private meeting, during the examination of a witness, any or all other witnesses in the matter being investigated by the legislative body.
- To confer on matters of litigation.

The act further enables the Board, pursuant to Government Code 54957.6, to meet prior to labor negotiations sessions to instruct its representatives concerning discussions regarding salaries and fringe benefits.

Per Resolution No. 1188-12 establishing a formal policy, that there shall be no audio or video recording of closed session meetings.

UNLAWFUL MEETINGS PENALTY:

Each member of a legislative body who attends a meeting of such legislative body where action is taken in violation of any provision of this chapter, with knowledge of the fact that the meeting is in violation thereof, is guilty of a misdemeanor.

MANDAMUS OR INJUNCTION:

Any interested person may commence an action either by mandamus or injunction for the purpose of stopping or preventing violations or threatened violations of this chapter by members of the legislative body of a local agency.

COURT COSTS:

A court may award court costs and reasonable attorney fees to the plaintiff in an action brought pursuant to Section 54960 where it is found that the local agency has violated the provisions of this article. Such costs and fees shall be paid by the local agency and shall not become a personal liability of any public officer for employee thereof. A court may award court costs and reasonable attorney(s) fees to a defendant in any action brought pursuant to Section 54960 where the defendant has prevailed in a final determination of such action and the court finds that the action was clearly frivolous and totally lacking in merit.

SECTION 11

PARLIAMENTARY PROCEDURE AND RULES

Meetings shall be governed by *Rosenberg's Rules of Order - Revised* where it is not in conflict with these By-laws. Notwithstanding any rule of parliamentary procedure, any officer of the Board of Directors shall have equal power with any member of said Board, and to take part in the discussion and vote thereon. A violation of these rules shall not constitute a basis for overturning an action of the Board.

SECTION 12

ADJOURNMENT OF BOARD OF DIRECTORS' MEETINGS

Notice of the time and place of holding an adjourned meeting shall be given to absent Directors, if possible, if the time and place can be fixed at the meeting adjourned.

SECTION 13

QUORUM

A majority of the authorized number of Directors shall be necessary to constitute a quorum for the transaction of business, except to adjourn as hereinafter provided. Every act or decision done or made by a majority of the Directors present at a meeting duly held, at which a quorum is present, shall be regarded as the act of the Board of Directors, unless a greater number be required by law, except as otherwise specifically provided in the By-laws.

SECTION 14

ORDER OF BUSINESS FOR BOARD OF DIRECTORS' MEETINGS

Per Resolution 1200-13, the order of business at regular meetings shall be as follows. The Board of Directors, by majority vote or in the direction of the Board Chair, may change the order of business.

1. Call Meeting to Order
2. Roll Call
3. Pledge of Allegiance
4. Closed Session
5. Public Comment (5:30 p.m.)
6. Consent Agenda
7. Regular Agenda
8. Committee, Director's, Manager's & Staff Reports
9. Correspondence
10. Unfinished Business
11. Board Items for Next Agenda
12. Adjournment

SECTION 15

MINUTES OF THE BOARD OF DIRECTORS MEETINGS

Per Govt. Section Code 61045 (d); All regular and special Board of Directors' meetings will be recorded electronically, if possible. The District Secretary will attend the Board meetings and compile written action minutes from the electronic recording and/or written notes, and these draft minutes will be presented to the Board of Directors within ten business days for their review. The District Secretary shall receive comments and corrections from Directors to be incorporated into the draft minutes and presented to the Board of Directors at the next regularly scheduled meeting for their final review and approval. These written minutes may be amended by the Board of Directors by majority vote. The electronic recording or written notes of the meeting will be erased or destroyed a minimum of 30 days after the meeting, but not before the written minutes are approved. Upon approval, the final approved minutes will be posted to the District website.

SECTION 16

DISRUPTION OF BOARD MEETINGS

It is hoped that most disruptions will be prevented by simply notifying the public in advance when they will be called upon to comment. Part 1 of the following procedure is suggested for this purpose. However, if a disruption occurs, the Board must be ready to deal with it in an orderly manner so that the Board may continue with its agenda. Out of fairness to the public, the persons causing the disruption and to law enforcement officials, the Board must make its position clear to all concerned. Silence on the part of the Board could be construed as suggesting that the disruptive behavior is permissible.

The following procedure should be followed:

1. BEFORE DISRUPTION OCCURS

Prior to any disruption occurring, and to prevent disruptions, the Chairperson should:

- a. Announce at the beginning of each meeting and have printed on the agenda the rules to be applicable during the meeting with respect to public participation. The agenda provides for public comment at a specified time. Normally, public comment is presented at times were indicated as agenda items or at specified public hearings.
- b. This causes law enforcement officers to be notified in advance when it is known that particularly controversial items on the agenda may cause disruptive behavior.
- c. Advise the public, when appropriate, of the rules applicable during the meeting. This should be done, for instance, when a controversial item on the agenda is reached, or at other times when disruptive behavior appears likely.
- d. Consider calling a brief recess to allow a cooling-off period if a disruption appears likely.

2. AFTER DISRUPTION OCCURS

When, in the opinion of the Chairperson or any other Board member, any person or group engages in activities during the Board meeting that impair the conduct of the meeting, the Chairperson should:

- a. Advise the person causing the disruption that he/she is disrupting the meeting.
- b. Advise him/her further of the established rules for conduct of the meeting.
- c. Advise him/her to adhere to these rules and to cease the disruption.

Hopefully, the first three steps outlined above will bring the disruption to an end. However, if the disruption continues, the Chairperson should:

- d. Consider calling a brief recess to allow a cooling-off period.
- e. If a recess was called but was not effective, or if no recess was called, request that the person causing the disruption to leave the meeting.
- f. If the person refuses to leave the meeting voluntarily and continues to cause a disruption, law enforcement officers present at the meeting should be requested by the Chairperson to remove the person from the meeting. If no law enforcement officers are present at the meeting, the meeting should be recessed until they can be summoned. (It is anticipated that the officers will begin arriving within 2 to 5 minutes, but a recess of at least 10 to 15 minutes is recommended. The reason for the recess should not be announced as this could inflame the situation. It may not be necessary to use the officers if the disruption does not resume when the meeting reconvenes.)
- g. If a group or groups are involved in the disruption and order cannot be restored by the removal of the individuals who are disrupting the meeting, the Chairperson should order the meeting room cleared, and the meeting should continue in session on matters appearing on the agenda. Action should not be taken on any matters not appearing on the agenda during such a session. Duly accredited representatives of the news media, except any who participated in the disturbance, shall be allowed to attend this session. In addition, other individuals not responsible for the willful disruption of the orderly conduct of the meeting shall also be readmitted.

SECTION 17

STANDING BOARD COMMITTEES

The following standing committees shall be appointed by the Board of Directors' Chairperson in January of each year:

PERSONNEL, POLICIES & PROCEDURES

- Review and recommend staff salary and wages.
- Review general staffing needs.
- Review job descriptions
- Review and recommend other personnel matters as needed.
- Budget study and review (personnel).
- Meet as needed to observe daily operation.
- Conduct initial interviews for positions vested in the Board and provide recommendations to the entire board.

FINANCE

- Review and recommend equipment and projects for Fixed Assets.
- Review budget and general finance items as needed.
- Review short- and long-term capital improvement plan.
- Budget study and review (income and expense).

- Evaluate development and assessment fees as needed.

PARK AND RECREATION

- Visit facilities and review needs.
- Review City and County general plan and District Master Plan as well as respective implementation status for each.
- Review and recommend various facility-use agreements as needed.
- Serve as liaisons to other public agencies.
- Meet as needed on program and facility-related items.

Each of these standing committees will review their appropriate areas and report to the Board of Directors their findings at least one or two times per year. The first meeting should be spent formulating the goals of the group and the positive impact they can have on the overall review of the staff, program areas, facilities, finances, and General Manager.

The standing committees will informally observe daily operations at least one or two times per year. The standing committees will not provide direction but will observe only to allow Board Members a clear understanding of the daily operations of the District.

Per Resolution No. 511-89, the Chairperson is empowered to appoint additional ad-hoc committees as needed, and Board liaisons to other agencies and organizations.

SECTION 18

FUNCTIONS OF THE STANDING AND AD-HOC COMMITTEES

STANDING COMMITTEES:

The Feather River Recreation and Park District Standing Committees meet the definition of a legislative body as indicated in California Government Code 54952(b):

A commission, committee, board, or other local agency, whether permanent or temporary, decision-making, or advisory, created by charter, ordinance resolution, or formal action of a legislative body. However, advisory committees composed solely of the members of the legislative body which are less than a quorum of the legislative body are not legislative bodies, except that standing committees of the legislative body irrespective of their composition which have a continuing subject matter, jurisdiction, or a meeting schedule fixed by charter, ordinance, resolution, or formal action of a legislative body are legislative bodies for purposes of this chapter.

1. Under California Government Code 54953, all meetings of a legislative body of a local agency shall be open and public, and all persons shall be permitted to attend any meeting of the legislative body of a local agency, except as otherwise provided in this chapter.

2. It is recommended that the terms of office of committee members be staggered to assure continuity on pending issues.
3. Committees will meet on an as-needed basis. It is recommended that committee meetings for study or research include staff to ensure effective communication, input and direction.
4. Committee reports will be given to the Board of Directors at regularly scheduled meetings concerning Committee business.

AD-HOC COMMITTEES:

The Feather River Recreation and Park District Ad-hoc Advisory Committees may or may not be legislative bodies as specified in the Government Code.

1. To avoid confusion in the interpretation of the Brown Act requirements, the Feather River Recreation and Park District will treat ad-hoc advisory committees in the same manner as standing committees.
2. Ad-hoc advisory committees can be appointed on an as-needed basis and may only meet on items associated with assigned responsibility.

SECTION 19

DISTRICT EMPLOYEES**PERSONNEL RULES:**

The Feather River Recreation and Park District Board of Directors shall adopt District personnel rules to provide a consistent, equitable and efficient program of personnel administration. The rules are available in the Employee Handbook at the District office.

SALARIES:

The Board of Directors will establish a classification plan, salary range and salary schedule for all full-time positions. The General Manager will establish the classification plan and salary range for all part-time positions and submit it to the Board of Directors for approval.

GENERAL MANAGER:

The Secretary of the District shall be called the General Manager and per Govt. Section code 61050 shall be hired by the Board of Directors under contract. Under the direction of the Board of Directors, the General Manager shall plan, organize, and direct the district-wide recreation, park, and leisure service operation and related work of the District. The General Manager's duties may include, but are not limited to, the following:

- Administers a comprehensive recreation and parks program for the service community.
- Plans, supervises, and directs the activities of the recreation and parks division in accordance with Board policy and direction.
- Recruits, selects, and employs District personnel; supervises the training, assignments, and organization of department personnel.
- Develops and maintains good working relationships among staff members.
- Supervises the acquisition, planning, design and construction of all recreation and park facilities; administers the operation and maintenance of all recreation and park facilities and areas.
- Prepares the District budget; executes and accounts for the expenditure of District funds in accordance with budget appropriations.
- Promotes the community, recreation and parks program and its philosophy and objectives to the public.
- Acts as a liaison to community organizations designed to further recreation and park programs and facilities; encourages clubs and organizations to sponsor community recreation and park programs.
- Prepares documents, reports, agreements, or manuals for Board members, personnel, and other public or private organizations as needed or when requested by Board members.
- Represents the District in relations with other governmental and private entities.

DISTRICT PERSONNEL:

The General Manager shall establish and implement duties, rules, procedures, and manuals for all District employees and volunteers with Board approval.

ANTI-FAVORITISM POLICY:

There is no bar to employment of relatives in the district except where one of them would exercise a supervisory role in relation to the other, or if relatives are in job positions in which a conflict of interest could arise. For this purpose, a relative is defined as a spouse, child, parent, sibling, grandparent, grandchild, aunt, uncle, cousin, corresponding in-law, "step" relation, or anyone related by marriage who is residing in the same household.

If two employees become "relatives" as defined above and are in a supervisory relationship or in job positions in which a conflict of interest could arise, the employees will have 30 days to decide which employee will stay in his or her current position. If this decision is not made within 30 days, the District Manager will make the decision, considering the employment history, seniority, and job performance of both employees, as well as any other relevant factor. The District Manager has the discretion to determine whether the employee will be retained or otherwise transferred to an available position.

SECTION 20

DISTRICT BUDGET PRESENTATION

The District Board of Directors shall adopt an annual budget for the fiscal year that shall represent the best judgment of the Board, community, and staff.

The General Manager shall submit a budget calendar to the Board of Directors at the January meeting as follows:

1. Feather River Recreation and Park District Board of Directors will allow public comment and discussion during the Public Hearing concerning the preliminary budget.
2. Adopt final Feather River Recreation and Park District budget.

The General Manager shall submit a draft budget each year in accordance with the Public Resources Code, Section 5780 to the Board of Directors no later than June 30 for the ensuing fiscal year.

SECTION 21

DISTRICT FINANCES

ANNUAL BUDGET:

The District's approved annual budget for the fiscal year will establish the guidelines for all expenditures associated with the general operations of the District. Expenditures for emergencies and special projects, not planned for at the start of the fiscal year, will be under the authority of the Board of Directors.

BUDGET SCHEDULE	TASK
1. January.....	Review budget process with staff
2. March.....	Full-time salaries and benefits Projected revenue from taxes Estimated utilities costs Recreation program budget Park/maintenance budget Capital outlay proposals
3. March.....	Review budget with staff
4. April.....	Board budget workshop

5. April.....Benefit Assessment oversight community input
6. May.....Approval of preliminary budget
7. June.....Public Hearing date
Adoption of appropriation limitations
8. July.....Adoption of final budget
9. July 31st.....Submit final budget to County.

RECEIPTED INCOME:

- Income in the form of checks, cash, and credit card payments for program fees, facility rentals, donations, etc. are received from walk-ins, mail-ins, on-line or collection from events off-site. These funds are counted, verified, and posted to the correct accounts using the District's computerized registration program. Checks, cash, and credit card payments are held in the cash drawer until the end of the business day when all income is secured in the safe. On the following business day, the prior day's income is counted and reconciled to the computerized registration accounts summary and deposited at the bank/Butte County Treasury. A copy of the deposit receipt and account summary are given to the Business Manager.

RESTRICTED RESERVE:

- The Feather River Recreation and Park District Board of Directors will establish by resolution a Petty Cash Reserve of \$1,000.00 each fiscal year. The Board of Directors may also establish, by resolution each fiscal year, an Accumulative Capital Outlay Reserve, and a General Contingency Reserve. If established, the Accumulative Capital Outlay Reserve and the General Contingency Reserve amounts will be set each fiscal year. Accumulative Capital Outlay Reserve funds will be obligated to structures, improvements, or equipment.
- Accumulative Capital Outlay Reserve and General Contingency Reserve funds may be transferred by resolution to the general fund by a four-fifths (4/5) vote of the Board of Directors. These funds may also be transferred by resolution from reserve to the current budget for expenditure in their obligated designation by a four-fifths (4/5) vote of the Board of Directors during the current year or by simple majority and resolution during the annual budget procedure.
- All resolutions concerning Restricted Reserves will be forwarded in their original form to the Butte County Auditor's Office for the County's records.
- Carryover funds are not a reserve and should not be used to balance a budget.

COLLECTION OF TAXES:

- The Butte County Treasurer will be responsible for the collection and deposit of all tax revenue for the District. The District will pay the County of Butte for this service.

EXPENDITURES:

- Warrants (checks) will be issued for payroll and payment of bills. Warrants will be signed by the General Manager and one board member, or in the absence of the General Manager, two Board members will sign. Registers will be drafted to verify all warrants. All registers must be signed by one Board Member and the General Manager, or in the absence of the General Manager, two board members. Registers must be signed prior to warrants being issued.
- Checks will be issued for refunds and transfers. Checks will be signed by the General Manager and one board member or in the absence of the General Manager, two Board members will sign.
- Reports of all warrants and checks issued each month will be given to the Board of Directors at a Finance Committee meeting and then again at the regular Board meeting. This report will include the warrant or check number, payee, item identification, amount, and the account fund. This report will be presented to the Board of Directors for their review and approval.

DEPOSITARY:

- All monies received by credit card by the District are deposited in a checking account at an accredited financial institution within the District's service area. Refunds and transfers are made from this account. The income withdrawal check from this account is made payable to the Butte County Treasurer where it is deposited in the District's General Fund. The District has established separate funds at the County for operations, donations, grants, endowments, scholarships, and impact fees.

FINANCIAL REPORTS:

- An account record of budgeted revenue, accounts receivable, accounts payable and expenditures shall be kept and a statement showing the end of the month results shall be presented to the Board of Directors at their regular monthly Board of Directors meeting. An end of the year final report will be presented to the Board of Directors at their regular meeting once the County and the District have reconciled both the revenue and expense accounts.

BONDS OF EMPLOYEES:

- All officers and employees of the District shall be bonded by a corporate security. The bond will be a \$250.00 deductible \$50,000.00 insurance agreement and kept annually. This bond will be paid for by the District.

LINE-ITEM TRANSFER:

- By resolution, the FRRPD Board of Directors has authorized the General Manager to initiate line-item transfers in the District budget as needed to conduct District business. Any line-item transfer made by the General Manager requires approval by

two Board members and will be documented and made available for review and, if necessary, ratification by the Board of Directors at the next Board meeting.

SECTION 22

DISTRICT AUDIT

The Board of Directors will contract with a professional accountant or firm to conduct an annual audit of the District's financing system. The results of the audit will be presented to the Board of Directors at a regular Board of Directors meeting. The District will rotate auditors, the District will send out a request for proposal (RFP) and/or a request for qualifications (RFQ) every three years and will change auditors on the fourth year.

SECTION 23

PURCHASE PROCEDURE POLICY

The following purchase procedures have been established to control the way District personnel spend funds that have been entrusted to the District. As stewards of public money, all District employees must comply with this responsibility in the highest standard of trust, professionalism, and integrity. All receipts must contain a budget classification code and a budget classification description from the Department Head, and with the General Manager's approval. Expenditure receipts under the authority of a supervisor should also have their initial approval.

The following procedures are applicable for all purchases except Service Contracts, Monthly Utilities and Fuel.

1. All expenditures must have prior Board of Directors approval, either in the approved operational budget, other approved designated funds, or by the Board.
2. All Expenditures above \$5000.00–\$24,900 Must have a written description of the expenditure, three (3) written estimates, professional planning, or design (as needed), contract if required, authorization from the General Manager, and Board of Directors prior consent to proceed.
3. Bidding procedure for expenditures of \$25,000.00 and over
 - a. Prior Board of Directors' approval.
 - b. A Request for Proposal Notice will be placed in a local newspaper of general circulation in the District for a minimum of one (1) time.
 - c. Notice will state the work to be done and where supporting documentation can be picked up, if needed.

- d. Notice will be posted at least seven (7) days before the time specified for receiving bids.
- e. Board may:
 - i. Accept the lowest bidder.
 - ii. Reject all bids and re-advertise.
 - iii. By a four-fifths vote, elect to purchase the materials or supplies in the open market.
 - iv. By four-ninths vote, elect to construct the building, structure, or improvement by force account.

At the discretion of the Board of Directors any purchase may be subject to a higher procedure category than listed.

SECTION 24

PETTY CASH FUND

The petty cash account will be set at \$1,000.00. This fund shall be set aside for the purpose of making change or purchases of small amounts. The fund will be replenished by a warrant approved by the Feather River Recreation and Park District Board of Directors and charged to the proper budgetary expenditure accounts. A normal range of expenditure would include items of \$25.00 or less.

The responsibility for the expenditures from the petty account will be limited to those positions authorized to handle daily cash receipts. The General Manager and the Business Manager shall be responsible for, and maintain, adequate accounting for this fund.

SECTION 25

PROCEDURES FOR PETTY CASH FUND

AUTHORIZATION:

1. **Cash to personnel making purchase:**
 - a. A petty cash voucher with the Supervisor's or Finance Manager's signature of approval indicating item, estimated cost, and the account to be charged will be submitted to the General Manager or the Business Manager.
 - b. Upon receipt of the voucher, the General Manager or Finance Manager will give cash in the amount of estimated cost to the person making the purchase.
 - c. Employee will sign the voucher as receiving cash and leave it with the General Manager or Finance Manager.

- d. After purchase, the paid invoice or receipt and change, if any, shall be returned to the General Manager or Finance Manager within the same day or the following business day if on a weekend.
 - e. The General Manager or Finance Manager will verify the amount of the invoice, change returned, and initial the voucher. Personnel will be reimbursed for any additional money spent out-of-pocket.
2. **Personnel Out-of-Pocket Expense:**
- a. Employees will present a paid invoice or receipt to the General Manager or Finance Manager as soon as possible after the purchase.
 - b. The invoice must show the Supervisor's signature of approval and the account to be charged.
 - c. No money shall be disbursed without such receipts.
 - d. Employees shall sign all receipts indicating that cash has been received.
3. **Accounting:**
- a. Paid bills and vouchers will be filed in a petty cash envelope until the fund needs replenishing.
 - b. The Finance Manager will transfer the accounting information from the voucher or paid invoice to a balance sheet located in the 'Petty Cash' money bag. Total of paid invoices, plus balance of cash, must always, be equal to the total amount of the Petty Cash Fund.
 - c. When the fund needs replenishing, the paid bills will be totaled and attached to an account distribution slip and processed with other accounts payable for the month. The warrant will be drawn in the name of the Feather River Recreation and Park District in the amount of the expenditures.
 - d. The proper budgetary accounts will be charged from the account distribution information.

SECTION 26

LEASES, CONTRACTS, ETC.

All leases, contracts, etc. entered by the Feather River Recreation and Park District Board of Directors and receiving Board of Directors' approval shall be signed by the Chairperson and Secretary, or the General Manager on behalf of the District when prior approval is given by the Board of Directors.

SECTION 27

SERVICE CONTRACTS

Notwithstanding any other provisions of these By-laws, the Feather River Recreation and Park District Board of Directors may negotiate a contract, and publicly soliciting bids with any persons or firms for furnishing to the District special services and advice in financial, economic, accounting, engineering, legal, administrative matters, or any other special service determined by the Board of Directors, if such persons or firms are specially trained, experienced, and competent to perform the special service required. The Board of Directors' conclusion to negotiate a contract therefore shall be conclusive.

SECTION 28

SURPLUS PROPERTY

The Feather River Recreation and Park District Board of Directors may declare as surplus, personal property owned by the Feather River Recreation and Park District which is not required for District purposes, or which should be disposed of for the purpose of replacement, or because it is unsatisfactory, or not suitable for District use.

Sub-sections:	29.010 Applicability
	29.020 Determination of Surplus Property
	29.030 Manner of Disposal
	29.040 District Personnel Prohibited
	29.050 Sale procedure
	29.060 Deed – Additional Costs
	29.070 Funds
	29.080 Effect on Validity
	29.090 Forms

29.010 Applicability.

The procedures set forth in this chapter shall be applicable to the disposal of real property owned by the District and determined to be surplus and excess property no longer necessary for District purposes. The provisions of this chapter shall not apply to the vacation of easements owned by the District and governed by the statutes of the state of California, the termination, rejection of abandonment of offers of dedication pursuant to Section 66477.2 of the Government Code, or the purchase of real property by a public agency pursuant to Section 54220 et seq. of the Government Code.

29.020 Determination of Surplus Property.

1. On or before December 31st of each year, District staff shall submit to the General Manager a report showing any real property in the possession, custody or control of the District that is no longer used and is otherwise surplus and excess for the needs of the District in compliance with Section 50569 of the Government Code. If the General Manager finds that such real

property is not required for any other public use, he or she shall so report to the Board of Directors and the Board of Directors may declare it surplus, authorize a public sale of the property, and cause to be prepared a written estimate of its market value.

2. Prior to disposal of surplus real property by public sale:
 - a) The Board of Directors shall review the disposition of the surplus real property for conformance with the District's Master Plan and issue a report confirming such conformity to Section 65402 of the Government Code; and
 - b) The General Manager shall provide notice to public agencies in the manner prescribed in Section 54220 et seq. of the Government Code. If no public agency wishes to purchase or lease the property pursuant to Section 54220 et seq. of the Government Code, the property shall be disposed of pursuant to the provisions of this chapter.

29.030 Manner of Disposal.

1. The General Manager may dispose of any surplus real property that has an estimated value of less than five thousand dollars (\$5,000.00) without complying with Section 29.050.
2. If the surplus real property has an estimated market value of five thousand dollars (\$5,000.00) or more, the General Manager shall dispose of the property in the manner set forth in Section 29.050.
3. If the parcel that is surplus real property is not a buildable parcel by itself under the current zoning, as determined by the Department of Community Development in either Butte County or the City of Oroville depending on where the real property is situated, then the General Manager may negotiate a sale price with the adjoining property owner(s) without complying with Section 29.050; provided, however, that the General Manager shall obtain Board of Directors approval for the final agreement of sale.
4. If the parcel that is surplus real property is a buildable parcel under the current zoning, and the combining of the parcel to an adjacent parcel would provide better development from a planning perspective than development of the surplus property by itself, as determined by the Director of Community Development, then the General Manager may negotiate a sale with the adjoining property owner(s) without complying with Section 29.050; provided, however, that the General Manager shall obtain Board approval for the final agreement of sale.

29.040 District Personnel Prohibited.

No District official, officer or employee shall bid, or be financially interested in any bid for surplus real property sold in accordance with this chapter.

29.050 Sale Procedure.

The conveyance of surplus real property by the District shall be by quitclaim of all right, title and interest in said property held by the District to the highest responsible bidder who submits a responsive bid pursuant to the following procedures:

1. A notice inviting bids shall be published at least once ten (10) days before the opening of the bids in a newspaper of general circulation in the city printed and published within the county. Notice inviting bids shall include a legal description of the subject property, a vicinity map showing the general location of the subject property, the time and place of opening of bids, specifications for bids, and a statement that transfer of the surplus real property shall be by quitclaim deed.
2. Sealed bids, including a ten percent (10%) bid deposit, shall be submitted to the General Manager. Said bid deposit shall be in the form of cash, cashier's check, certified check, or bidder's bond executed by an authorized surety company.
3. At the time and place fixed in the notice to bidders, all sealed proposals which have been received shall be officially opened, examined and declared by District staff. Of the proposals submitted which conform to all terms and conditions of sale, the proposal which is the highest shall be accepted unless a higher oral bid is accepted, or the General Manager rejects all bids.
4. In his or her sole discretion, the General Manager may set a minimum acceptable bid amount and may reject all bids presented.
5. After opening bids, District staff shall call for oral bids from those bidders tendering written proposals. If, upon the call for oral bidding, any responsible person offers to purchase the property, upon the terms and conditions specified and for a price exceeding by at least five percent (5%) of the highest written proposal, and thereafter by successively higher bids by at least five percent (5%) of the highest written proposal, then the responsible oral bid which is the highest shall be accepted. Final acceptance by the General Manager shall not be made, however, until the oral bid is reduced to writing and signed by the offeror and an additional cash deposit (in cash, cashier's check or certified check) in the amount of ten percent (10%) of the bid over the offeror's original bid is tendered. This reduction of the bid to writing with signature and cash deposit shall be completed within twenty-four (24) hours after determination of the highest bidder has been declared by the General Manager, or the offeror shall forfeit his bid deposit.

6. Upon determination of the highest bidder pursuant to subsection six of this section, the General Manager shall obtain Board of Director approval for the final agreement of sale and authorization to execute a quitclaim deed on behalf of the District.
7. The successful bidder shall pay the balance of the purchase price plus all incidental and ancillary costs within fourteen (14) days of Board of Directors approval of the final agreement of sale unless an extension is agreed to by the Board of Directors. Failure to submit the balance and all such costs with fourteen (14) days (or as may be extended) shall result in forfeiture of the bidder's deposit. Unless otherwise specified in the notice to bidders, sale of surplus property shall be made for cash, cashier's check, or certified check.
- 8.
9. All bidders' deposits shall be retained until the quitclaim deed is recorded and shall then be returned, except as provided in subsection seven of this section.

29.060 Deed – Additional Costs.

All incidental and ancillary costs, including but not limited to escrow fees, commissions, title and recording fees, shall be borne exclusively by the purchaser.

29.070 Funds.

The amount received for any property sold pursuant to these rules shall be credited to the appropriate fund as the Board of Directors may determine.

29.080 Effect on Validity.

Nothing in this chapter shall affect the validity of any transfer of title to real property.

29.090 Forms

The following form for notice to bidders and resolution accepting bids may be used:

FEATHER RIVER RECREATION & PARK DISTRICT NOTICE
TO BIDDERS OF SALE OF SURPLUS PROPERTY

The Feather River Recreation & Park District has determined that the property described in *Exhibit A* which is attached hereto is surplus and no longer necessary for public purposes. Said real property is located at (DESCRIPTION OF PROPERTY).

The Feather River Recreation & Park District desires to sell the herein described property to the highest responsible bidder by quitclaim deed. The Feather River Recreation & Park District makes no representations regarding this property, including but not limited to its size, zoning, utility service or accessibility, or presence of hazardous materials. While the subject property was acquired in fee by the Feather River Recreation & Park District in connection with (DESCRIPTION OF PROJECT), the Feather River Recreation & Park District makes no warranties express or implied about title of this property.

Sealed bids, subject to the conditions named herein, addressed to the Feather River Recreation and Park District will be received at the Feather River Recreation and Park District office located at 1875 Feather River Blvd., Oroville, CA 95965 up to 2:00 p.m. (DATE BIDS DUE), at which time they will be officially opened and read. The right is reserved as the interests of the Feather River Recreation and Park District may require, to reject all bids, to waive any informality in bids, and to accept or reject any items of any bid.

The Feather River Recreation and Park District further reserves the right to accept oral bids from responsible bidders who have submitted written bids exceeding by at least five percent (5%) of the highest written bid.

All incidental or ancillary fees associated with the transfer of this property by quitclaim deed, including but not limited to title insurance, escrow fees, commission, notaries, recording fees and the like shall be borne exclusively by the purchaser without recourse to the Feather River Recreation and Park District.

A Bid Deposit shall be placed in an envelope attached to the outside of the sealed proposal. The Bid Deposit shall be in one of the following forms: cash, cashier's check, certified check, or bidder's bond executed by an authorized corporate surety. Checks or bonds shall be in an amount equal to at least ten percent (10%) of the total amount of the bid.

SECTION 29

CERTIFICATES OF APPRECIATION OR RECOGNITION

Certificates of Appreciation or Certificates of Recognition shall be presented, but not limited to, volunteers, donors, and leaders of various organizations as recommended by the General

Manager, Board Chairperson, or Board and approved by the Feather River Recreation and Park District Board of Directors.

SECTION 30

FACILITY/PROGRAM USE AND FEES

The Feather River Recreation and Park District Board of Directors establish these fees and authorize the General Manager to administer the policy concerning facility/program use and fees charged for District facilities and programs.

ORDER OF PRIORITY:

Buildings, grounds, and recreational facilities under management of the District will be available for use by the general public. Uses may be sponsored or co-sponsored by the District. When buildings, grounds, and recreational facilities are not in use by the District, they will be available by application to other community groups and individuals in accordance with the following:

1. Public agencies' sponsored programs.
2. Youth-serving agencies or organizations which are recognized and whose objectives and activities are consistent with the general recreation and youth services programs of the community. These include, but are not limited to, Girl Scouts, Boy Scouts, 4-H Club, Little League, Swim Team, Boys and Girls Club, and Oroville Youth Soccer Club, and the YMCA.
3. Other local community agencies or organizations whose activity is community-wide in nature, and which is consistent with the objectives of the Feather River Recreation and Park District.
4. Private usage for individuals or groups with no immediate relation to the general purposes of the community recreation program. These include, but are not limited to, receptions, reunions, and weddings. These events are scheduled only as space is available with higher priority given to the agencies or organizations listed above.

PROGRAM FEES:

Program fees for Feather River Recreation and Park District programs will cover all the total program costs and be under the direction of the General Manager. Fees will vary from one program to another because of variation in personnel, supplies, and facility costs. Accounts receivable and accounts payable reports will be generated and provided to the Board monthly.

The General Manager will recommend and establish fees for programs and present them to the Board of Directors for approval.

Fee Waiver Requests: Fee waivers may be granted to 501c3 non-profit organizations, schools, service clubs or other public agencies. The General Manager may approve fee waivers from 10%-50% of the rental fee.

Co-Sponsorship Requests: The General Manager may approve the co-sponsorship of free public events up to a \$500 fee waiver provided the district budget can support it. If the co-sponsorship exceeds \$500 in cost to the district, the request will be sent to the Finance Committee and then to the Board of Directors for consideration. As a condition to such waiver, the district logo will appear on advertising for these events.

General guidelines concerning program fees are listed below:

OTHER INFORMATION REGARDING FEES:

1. All individuals, agencies, or organizations will be charged if their function is determined to be commercial in nature.
2. All confirmed reservations will be honored unless a situation should arise where a cancellation is required. The General Manager or the General Manager's designee will determine such cases and up to a full refund may be given.
3. All reservations may require other fees and responsibilities depending on the nature of the activity such as, but not limited to, dump fees, portable toilet fees, or professional staff fees. The General Manager or the General Manager's designer will determine additional fees as needed.
4. A facilities attendant and or maintenance employee may be required to be assigned when groups are meeting in Feather River Recreation and Park District facilities. This will include set up time, program time, and clean up. The fee, when charged will be the board approved facility use fee schedule fee.

SECTION 31

INJURY AND ILLNESS PREVENTION PROGRAM

The Feather River Recreation and Park District Board of Directors have adopted an Injury and Illness Prevention Program in compliance with Senate Bill 198. The General Manager is responsible for keeping this program active and up to date. Any recommended changes to this program will be presented to the Board of Directors for their review and approval.

SECTION 32

FIXED ASSETS

To safeguard the investments of the District, the Board of Directors has established a Fixed Assets inventory list for accountability and record keeping. All District property and records are to be kept and maintained on District premises. The General Manager and Finance Manager will be responsible for maintaining the inventory list.

SECTION 33

LIABILITY AND WORKERS' COMPENSATION INSURANCE

LIABILITY INSURANCE:

Per Resolution 1234-14 the Feather River Recreation and Park District Board of Directors has elected to join the Special District Risk Management Authority, a joint powers agency formed to provide coverage to member districts. Coverage includes general liability, public officials and employee's liability, automobile liability, property loss coverage, automobile physical damage, and boiler and machinery. This program of collective self-insurance is permitted under Government Code Sections 6500 and 990.8.

WORKERS COMPENSATION:

The Feather River Recreation and Park District Board of Directors have elected to join the Special District Risk Management Authority, a joint powers agency formed to provide coverage to member districts SDRMA.

SECTION 34

SECURITY AND RETENTION OF FORMS POLICY

SECURITY:

All personnel forms, discs, and other materials containing information that is considered confidential are to be maintained by the General Manager and kept in a locked file, locked storage area, or other facility that can be secured by a lock. These confidential documents will only be available to District personnel who are authorized by their job duties to access this information. Confidential personnel information that is stored on a computer will be protected by password and authorized computer access.

All personnel forms, discs, and other materials that contain confidential information that the FRRPD Board of Directors has approved to be discarded will be disposed of in the following order:

1. Documents will be disposed of by authorized personnel only.
2. Documents will be approved for disposal per the guidelines and retention schedule as per the *Records Retention Policy*.

3. Documents approved to be discarded will be identified prior to disposal. A list will be maintained, and a hard copy of the list will be kept in the safe and a digital copy will be backed up onto a USB thumb drive or C.D.
4. Authorized personnel who have discarded forms will sign a statement that documents were discarded properly.
5. All documents that have been approved to be discarded will be shredded in an appropriate manner and disposed of in a District trash bin.

POLICY FOR THE RETENTION OF RECORDS:

The FRRPD Board of Directors adopted a *Records Retention Policy* on October 14, 2009, whereby documents must be kept according to a retention schedule.

A copy of this document is attached. (EXHIBIT B)

SECTION 35

AMERICAN DISABILITIES ACT

In compliance with the American Disabilities Act (ADA), the District has adopted an Assessment and Implementation Plan for all District facilities. This plan will be updated as legally required to keep the District focused on providing and evaluating facility accessibility.

SECTION 36

AMENDMENTS TO THE FEATHER RIVER RECREATION AND PARK DISTRICT BY-LAWS

These Regulations or By-laws of the Feather River Recreation and Park District may be amended or modified by the Feather River Recreation and Park District Board of Directors by resolution adopted and approved by the Board of Directors, provided notice of the intent to amend these Regulations or By-laws and the proposed amendment(s) have been communicated to each Board Member and the general public in compliance with the Ralph M. Brown Act.

A chart listing the resolutions amending the Policies & Procedures Handbook is provided on the following page. Copies of these resolutions are included in Exhibit A.

SECTION 37

DISTRICT MAP

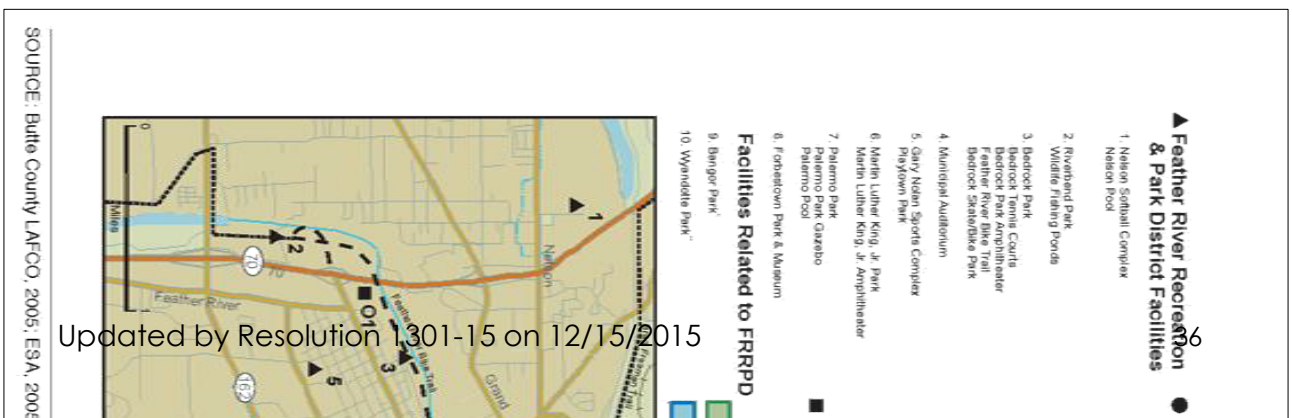

Updated by Resolution 1301-15 on 12/15/2015

ADDENDUM

ADDENDUM TO THE FEATHER RIVER RECREATION AND PARK DISTRICT BY-LAWS

PROCESS OF REJECTION OF BIDS AND FAILURE TO RECEIVE BIDS AS STATED IN THE COST ACCOUNTING POLICIES AND PROCEDURES MANUAL FOR THE GENERAL CALIFORNIA LAW PUBLIC CONTRACT CODE SECTIONS 20100, ET SEQ.

As a public agency, the Feather River Recreation and Park District may assert its discretion to reject presented bids if, prior to rejecting all bids and declaring that the project can be more economically performed by employees of the agency, a written notice is furnished to an apparent low bidder. The notice shall inform the bidder of the agency's intention to reject the bid and shall be mailed at least two business days prior to the hearing at which the agency intends to reject the bid. If after the first initiation for bids all bids are rejected, after re-evaluating its cost estimates of the project, the public agency shall have the option of either of the following:

1. Abandoning the project or re-advertising for bids in the manner described by this article.
OR
2. By passage of a resolution by a four-fifths vote of its governing body declaring that the project can be performed more economically by the employees of the public agency, may have the project done by force account without further complying with this article.
 - a) If a contract is awarded, it shall be awarded to the lowest responsible bidder. If two or more bids are the same and the lowest, the public agency may accept the one it chooses.
 - b) If no bids are received through the formal or informal procedure, the project may be performed by the employees of the public agency by force account or negotiated contract without further complying with this article.

EXHIBITS

EXHIBIT A:

AMENDMENTS TO THE FEATHER RIVER RECREATION AND PARK DISTRICT BY-LAWS

SECTION	AMENDMENT / CHANGE	RESOLUTION	DATE
—	Handbook approval	1206-13	03/12/2013
4,6,7,12,20,22, 2 4,25,26	General changes to Handbook	1210-13	04/09/2013
18	Committee Reassignments	1211-13	05/14/2013
Addendum	Rejection of bids	924-06	10/25/2006
Entire	Adoption of Updated Handbook	1252-14	12/09/2014
Entire	Review and Adoption of Updates	1300-01	12/15/2015
Entire	Review and Adoption of Updates		TBD

EXHIBIT B: SECURITY AND RETENTION OF FORMS POLICY

FEATHER RIVER RECREATION AND PARK DISTRICT
1875 Feather River Boulevard
Oroville, CA 95965
(530) 533-2011

Adopted by
FRRPD Board of
Directors
October 14, 2009,
To be revisited in
2023.

FEATHER RIVER
RECREATION & PARK DISTRICT

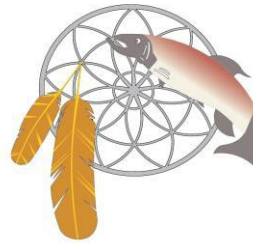

SECURITY AND RETENTION OF FORMS POLICY

October 14, 2009

SECURITY AND RETENTION OF FORMS POLICY

SECURITY

All personnel forms, discs, and other materials containing information that is considered confidential will be placed in a locked file, locked storage area, or other facility that can be secured by a lock. These confidential documents will only be available to District personnel who are authorized by their job duties to access this information. Confidential personnel information that is stored on a computer will be protected by password and authorized computer access.

All personnel forms, discs and other materials that contain confidential information that the Feather River Recreation and Park District Board of Directors has approved to be discarded will be disposed of in the following order:

- Documents will be disposed of by authorized personnel only.
- Documents approved to be discarded assuring whether the documents are confidential and will be identified prior to disposal.
- At least two authorized personnel who have discarded forms will sign a statement that documents were discarded properly.
- All documents that have been approved to be discarded will be shredded and disposed of in the district trash bin.

RETENTION OF FORMS

The Feather River Recreation and Park District Board of Directors adopted retention of forms policy on October 14, 2009, whereby documents must be kept for a period, in the format of either hard copy, hard drives, flash drive discs or other materials.

This Security and Retention of Forms Policy was further approved through the adoption of Resolution 1210-13 on April 9, 2013.

RETENTION OF DOCUMENTS AND FORMS GUIDELINES

The Feather River Recreation and Park District Board of Directors have approved the following guidelines regarding the retention of forms and documents, whereby documents must be kept for the time indicated.

Note: Before any items are discarded, an Archival Document(s) Reduction Request form must be completed and signed by the General Manager.

PERMANENT:

1. Annexations/Reorganizations
2. Articles of Incorporation
3. Audit Reports
4. Bonds
5. Deeds, Real Property
6. Easements, Real Property
7. Election Ballots, Prop. 218 Assessment Districts
8. Environmental Quality, Asbestos
9. Environmental Quality, California Environmental Quality Act (CEQA)
10. Environmental Quality, Soil Reports
11. Employee Retirement Income Security Act of 1974 (ERISA Records)
12. General Ledgers
13. Hazardous Materials, Underground Storage Tank Compliance Documents
14. Investment Reports, Transactions
15. Minutes (Board of Directors)
16. Property, Abandonment
17. Records, Management Disposition Certificate
18. Resolutions (Board of Directors)

30 YEARS:

1. Hazardous Materials, Exposure Reports, etc.

10 YEARS:

1. Accidents/Damage to District Property
2. Bonds, Final
3. Bonds, Development
4. California State Tax Records
5. Economic Interest Statements, Form 700 Originals, Elected
6. Employee Information, Payment
7. Employee Retirement Income Security Act of 1974 (ERISA Records), Plan Reports, Certified Information Filed
8. Payroll, Federal/State reports
9. Payroll, Registers

10. Payroll Records, Terminated
Employees 10 YEARS (continued):

11. Payroll, Timecards/Sheets
12. PERS, Employee Benefits
13. Property, Acquisition/Disposition

5 YEARS:

1. Accounts Payable/Receivable
2. Affidavits of Publication/Posting
3. Appraisals
4. Backflow Test Reports
5. Bank Account Reconciliations
6. Bids, Accepted
7. Bonds, Surety
8. Cal-OSHA, Personnel Logs, Supplementary Record, Annual Summary (Federal & State Cal OSHA)
9. Deferred Compensation Reports
10. Economic Interest Statement, Form 700 (copies)
11. Economic Interest Statements, Not Elected
12. Election, Affidavit Index
13. Election, Nomination Documents, Unsuccessful
14. Election, Roster of Voters
15. Election, Voter Affidavits
16. Election, Voter Registration Signature Copy
17. Employee Information, General
18. Environmental Quality, Air Quality (AQMD)
19. Fire Protection District Administration
20. Insurance, Risk Management Reports
21. OSHA, Log 200, Supplementary Record, Annual Summary (Federal & State OSHA)
22. Personnel Records, Other Than Payroll
23. Recruitments and Selection
24. State Tax Records
25. Unemployment Insurance Records

2 YEARS:

1. Agenda/Agenda Packets
2. Agenda Reports, Staff Reports
3. Audit Hearing or Review
4. Benchmark Data
5. Bids, Unaccepted
6. Bonds, Paid, Cancelled
7. Bonds, Unsold
8. Brochures, Publications
9. Citizen Feedback

10. Complaints, Requests
11. Correspondence
12. Election, Administrative Documents
13. Election, Ballots, and Identification Envelope, Federal Offices
14. Employee Information, California Employer Information Report (CEIR)
15. Employment Application, Not Hired
16. Employment, Surveys, and Studies
17. Hazardous Materials, Underground Storage Tank Maintenance and Repair
18. Information Systems, Network Information Systems (LAN/WAN)
19. Information Systems, Program Files, and Directories
20. Information Systems, Tapes
21. Legal Notices, Affidavits of Publication
22. Maintenance/Repair Records, Equipment
23. Marketing, Promotional Records
24. Meter Operations
25. Newsletter, District
26. Notices, Public Meetings
27. Paramedic Services
28. Political Support/Opposition, Requests and Responses
29. Press Releases
30. Public Records Request
31. Salary Surveys
32. State Controller
33. Stop Payments

1 YEAR:

1. Election, Ballots, and Related Documents
2. Election, Canvass
3. Election, Election Official's Package of Documents
4. Election Petitions, Initiative/Recall/Ref. Charter Amendments
5. Election petitions, No Election
6. Election, Precinct Records

90 DAYS:

1. Recordings, Videotaped, Other Than Public Meetings

30 DAYS:

1. Recording, Videotaped Meetings of Legislative Bodies

Hold the following records until existing conditions such as, but not limited to, employment, audit, settlement, termination, or status ends, plus:

30 YEARS:

1. Accident/Illness Reports
2. Employee, Medical Files
3. OSHA, Accident/Illness Reports

10 YEARS:

1. Hazardous Materials, Hazardous Waste Disposal
2. Oaths of Office
3. Payroll, Deduction/Authorizations
4. Payroll, Wage Rates/Job Classifications

5 YEARS:

1. Agreements (registration, waiver, etc.)
2. Annual Financial Report
3. Bonds, Employee
4. Checks
5. Claims Against the District
6. Collective Bargaining Agreements
7. Comprehensive Annual Financial Reports (CAFR)
8. Contracts
9. Deposits, Receipts
10. Election, Certificates of Election
11. Election, Nomination Documents, Successful
12. Employee, Non-Safety
13. Employee Safety (Safety Committee documentation)
14. Employee Eligibility Verification, I-9 Forms
15. Family and Medical Leave Act, Federal
16. Federal Tax Records
17. Fixed Assets, Surplus Property
18. Grants, Community Development Block Grant (CDBG), Urban Development, and Other Federal and State Grants
19. Purchasing Requisitions, Purchase Orders
20. Taxes, Special
21. Vouchers, Payments
22. Workers' Compensation Files

2 YEARS:

1. Budget, Annual
2. Demographic/Statistical Data
3. Employee Bonds
4. Employee Files
5. Employee Information, Applicant Identification Records
6. Employee Programs
7. Employee Recruitment

8. Employee Reports
9. Employee Rights, General
10. Employment, Training Records, Non-Safety
11. Employment, Personnel, By Name
12. Employment, Public Safety
13. Environmental Quality, Congestion Management
14. Environmental Quality, Environmental Review
15. Environmental Quality, Pest Control
16. Environmental Quality, Soil
17. Fire Safety Administration
18. Fixed Assets, Inventory
19. Fund Transfers
20. Gifts/Bequests
21. Hazardous Materials, Permits, Hazardous Materials Storage
22. Information Services, Internet/World Wide Web
23. Information Systems, Inventory
24. Insurance
25. Insurance, Joint Powers Agreement
26. Insurance Certificates
27. Insurance, Liability/Property
28. Invoices
29. Legal Opinions
30. Litigation
31. Maintenance Manuals
32. Meter Reading
33. Personnel Rules and Regulations
34. Petitions
35. Policies, Administrative
36. Policies, District Board
37. Procedure Manuals
38. Purchasing, RFQ's, RFP's
39. Records Retention Schedules
40. Returned Checks
41. Utility Services, Applications
42. Utility Services, Billing Records
43. Utility Services, Journals, Utility Billing
44. Utility Services, Meter Reading, Reports
45. Utility Services, Utility Rebates, Reports
46. Warrant Register/Check

Register HOLD UNTIL SOLD or

RELEASED:

1. Fixed Assets, Vehicle Ownership and Title

**FEATHER RIVER RECREATION AND PARK DISTRICT
1875 Feather River Blvd. • Oroville, CA • 95965
(530) 533-2011**

ARCHIVAL OF FORMS AND DOCUMENTS REDUCTION REQUEST

I AM REQUESTING THE GENERAL MANAGER’S APPROVAL TO DESTROY THE FOLLOWING FORMS AND DOCUMENTS BASED ON THE GUIDELINES ADOPTED IN THE RETENTION OF FORMS AND DOCUMENTS POLICY (OCTOBER 14, 2009):

(Please provide a complete description of the document, including document year: i.e., information systems, program files and directories, sports rosters, etc.)

Check the Box that applies:

CONFIDENTIAL

NON-CONFIDENTIAL

Submitted by: _____
(Staff Name)

Date: _____

Approved by: _____
(General Manager)

Date: _____

VERIFICATION OF DOCUMENT DESTRUCTION

Documents were destroyed by _____ **on** _____
(print name) *Date*

Employee Signature: _____

Witnesses Signature: _____



C1

STAFF REPORT

DATE: October 4, 2023

TO: FRRPD Board of Directors

FROM: Chris Wagoner, General Manager

RE: Union Contract

SUMMARY

The General Manager does not currently have authority to negotiate the union contract. I believe it is necessary for the General Manager to be involved in the details of the union contract and have the authority to negotiate.

RECOMMENDATION

Allow the General Manager to negotiate details of the union contract.

ATTACHMENTS:

Feather River Recreation and Park District UPEC Initial Proposal



United Public Employees of California, Local 792

Laborers' International Union of North America, AFL-CIO

"Serving Those Who Serve Our Communities"

1800 Park Marina Drive · Redding, California 96001-0913

530-245-1890 · Toll Free 800-241-1890 · Fax 530-246-1651 · www.upec792.com

Feather River Recreation and Park District UPEC Initial Proposal

Duration-

The memorandum of understanding between the Feather River recreation and park district ("District") and the United Public Employees of California local 792 ("Association" or "UPEC")-**July 1st, 2023 - October 31st, 2025.**

Compensation-

The Association proposes a 10% COLA upon the first pay period following ratification and approval of the successor agreement, with an additional 7% COLA effective September 1, 2023

New Article- Discipline

Discipline

The District may discharge or suspend from employment any member who has completed the specified probationary period only for cause. It is understood and agreed by both parties that bargaining unit employees are not "at-will" employees and have a property interest in their employment. As such bargaining unit members are entitled to due process prior to implementation of discipline including, but not limited to a pre-deprivation or "Skelly" hearing. Examples of conduct or performance deficiencies that may warrant discipline include, but are not limited to:

- A. Misstatement of facts during the hiring process;
- B. Falsification of any entry on a District document (e.g., time card, expense report);
- C. Disclosure of confidential information;
- D. Insubordination or willful disobedience;
- E. Incompetence, inefficiency, or unsatisfactory job performance;
- F. Discriminatory, discourteous or unbecoming behavior;
- G. Theft, misuse, or unauthorized use or possession of District property;
- H. Dishonesty;
- I. Misconduct (e.g. any behavior that brings harm or discredit to the District;
- J. Being under the influence of illegal drugs or alcohol or possessing illegal drugs while on District property or on official business.
- K. Conviction of a felony or misdemeanor that involves moral turpitude, or any other convictions of or pleas of nolo contendere (no contest) or diversion for such offense, which adversely affects or brings discredit to the District;
- L. Excessive absence or tardiness;
- M. Absence without approved leave;
- N. Violation of City rule, policy, or procedure; (e.g. violence in the workplace policy, unlawful harassment, etc.)

- O. Soliciting outside work from personal gain during the conduct of City business; engaging in outside employment for any business under contract by the City; participating in any outside employment that adversely affects the employee's city work performance; and engaging in unauthorized outside employment;
- P. Loss or failure to maintain any license, certification, and/or clearance which is required as a minimum qualification or condition of employment for the employee's position.

In the event a member feels the discharge or suspension is not for cause, the UPEC shall have the right to appeal the case through the grievance procedure.

Probationary members may be discharged for any reason, which in the sole discretion of the City is just and sufficient and such discharge shall not be subject to appeal.

Removal of Disciplinary Documents and Submission of Written Rebuttals

- a) The parties agree that Letter of Instructions, Counseling Memorandums and/or Letter of Reprimands are the first steps of progressive discipline.
- b) Letter of Instructions, Counseling Memorandums and/or Letter of Reprimands, and any and all related documents/materials, at the written request of the employee, will be removed from any and all of the employees personnel file(s) after two (2) years have elapsed. In any event, all adverse materials will be considered null and void after such two (2) year period with the following exceptions:
 - 1. If further disciplinary action concerning any misconduct occurs within two (2) years from the initial disciplinary action, then there will be no requirement to remove the adverse material. If there is no further disciplinary action concerning any misconduct within four (2) years from the last occurrence, at the written request of the employee, all adverse materials including all related documents, and materials, will be removed from the employees file and considered null and void.
 - 2. This provision does not apply to disciplinary suspension, demotion, termination, workplace violence or sexual harassment, if an employee has been found to be in violation of these items.
- c) An employee has the right to provide a written rebuttal to any of the above within thirty (30) days of receipt of the documentation which will be attached to the original document and placed in the employees official personnel file(s) in the Personnel Department.

Departmental Action Prior to Imposition of Discipline

Except in cases of emergency, at least five (5) calendar days prior to the effective date of any disciplinary action against members with permanent status, the department head or person authorized by him/her shall give the member written notice of the proposed disciplinary action, reasons for such action, a copy of the charges and material upon which the action is based, and the right to respond either orally or in writing, or both, to a neutral department head agreed to by the City Administrator and the OCEA who shall serve as the Skelly Officer. The department head who shall be designated the Skelly Officer shall be determined on a rotating basis. The department head of the department in which the member works will be ineligible to hear the Skelly appeal.

Notice of Disciplinary Action

Whenever a disciplinary action is taken against a member, the member shall be notified in writing. Such notification shall include but is not limited to:

- a) A statement of the disciplinary action taken against the member.
- b) A summary of the facts upon which the disciplinary action is based.
- c) A statement advising the member that written notice of the disciplinary action is to be placed in the member's official personnel file and that the member shall have the right to appeal under the grievance procedure as set forth in this Memorandum.

The written notice of disciplinary action may be either personally served or mailed to the member by certified mail, return receipt requested, addressed to the last address which the member has furnished the City.

Appeals of Discipline for Permanent Members

A member may appeal a disciplinary action by filing a grievance at Step 3 of the grievance procedure within ten (10) days of receiving the notice of disciplinary action.

LEAVES

UPEC proposes that the bargaining unit members receive paid time off in parity with the FRR&D office staff in December of each year.

Article 12.02 - Duration of Agreement

The articles in this agreement shall be effective and shall remain in full force and effect until midnight, October 31, 2025.

